

KOMATSU®

WB156-5 WB156PS-5

NET HORSEPOWER
70.8 kW **95 HP** @ 2200 rpm

OPERATING WEIGHT
7498 kg **16,530 lb**

WB
156

BACKHOE LOADER



Photos may include optional equipment

WALK-AROUND

The Dash 5 Komatsu Backhoe Loaders include the best from our previous series and add innovations for the future. The WB156-5 has the power, speed, balance, control, and operator comfort to be extremely productive in a very competitive world.

Spacious and comfortable operator station allows 360° visibility.

Adjustable seat, steering, and backhoe controls allow the machine to better fit any operator. Switches and gauges are clustered to simplify operation.

Corner mounted

exhaust enhances visibility

Tilting engine hood

can be opened when the loader is in the raised or lowered position

Powerful engine and hydraulics

70.8 kW **95 HP** engine combined with Komatsu's HydraMind hydraulic system provides fast, precise, and comfortable operation. Two working modes allow the operator to choose between maximum power and minimum fuel consumption.

Dual direction parallel lift loader linkage keeps the bucket or forks level throughout the lifting arc

Heavy-duty cast nose guard provides integral counterweight and front protection to the engine compartment

Large loader bucket

0.95 m³ **1.25 yd³** loader bucket with bolt-on cutting edge. Optional 0.99 m³ **1.30 yd³** multi-purpose bucket shown in walkaround photo.

Steering Cylinders

are mounted behind and above the front axle for protection from jobsite debris



NET HORSEPOWER
70.8 kW **95 HP** @ 2200 rpm

OPERATING WEIGHT
7498 kg **16,530 lb**

Front roof cutout provides a better view of loader at full height

Telescopic arm option increases dig depth to 5969 mm **19'7"**



S-Boom design provides superior visibility and helps the operator avoid obstructions when digging or loading trucks

Dual tapered backhoe buckets are equipped with Extreme Service (XS) adapters and teeth (optional)

Reversible outrigger pads accommodate both earth and paved surfaces

Photos may include optional equipment

Heavy-duty power shuttle transmission and axles

Optional PowerShift (WB156PS-5) for shift-on-the-fly with column-mounted lever

Large, lockable toolbox located under step

DASH-5 FEATURES



Tilting Steering Column

The steering column has a single lever that locks when released at the desired position.



Excavator Controls

Mounted on tilting towers with changeable control pattern.



Adjustable Wrist Rests

Maximize ergonomics and operator comfort.



Pilot Actuated Loader Joystick

Multi-function controls for loader, differential lock, declutch, speed-up, and optional 4-in-1 bucket control.

Clustered gauges and switches are in plain view and easy to reach.



Pilot Actuated Outrigger Levers

Provide smooth and precise control.



Corner Exhaust/Front Roof Cut-out

Provide an unobstructed view even when loader bucket is at full height.



S-Shape Backhoe

Enhances truck loading, improves visibility, provides strong breakout and lift capacities.



Dual Direction Parallel Lift

Mechanical linkage design keeps the load level from bottom to top (max 11° tilt back).



Extreme Service Buckets

Include XS adapters and multiple tooth designs for most applications.



Tiltable Engine Hood

Allows access to service check points. Locks with the ignition key.



Lockable Toolbox

Secure storage for tools, grease gun, etc.

OPERATOR STATION



The Dash-5 operator station is state-of-the-art. Interior appointments are rugged, yet elegant. The multiple seat and control adjustment mechanisms enable a better fit for both large and small operators and provide hours of comfortable operation. The canopy, or cab, has a true double-entry

platform. The climate controlled cab is quiet and has 10 vents for excellent air circulation. The cab's rounded shape provides a spacious and quiet environment. Visibility is unsurpassed. The one-piece rear window is easy and quick to open and close.

SPECIFICATIONS



ENGINE

ModelKomatsu S4D102LE-2
 TypeVertical, 4-cycle water-cooled diesel engine
 AspirationTurbocharged
 CombustionDirect injection
 Compression ratio18:1
 Number of cylinders4
 Piston displacement4.5 ltr **275 in³**
 Horsepower rating - **WB156-5/WB156PS-5**
 Gross horsepower @ 2200 rpm73.8 kW **99 HP**
 Net horsepower @ 2200 rpm (SAE J 1349)70.8 kW **95 HP**
 Max torque @ 1500 rpm414 Nm **305 ft lb**
 Lubrication system:
 MethodGear pump, force-lubrication
 FilterFull-flow type
 Air cleanerDry type with double elements and dust evacuator, plus dust indicator
 Cooling systemRadiator
 Starting systemElectric motor with air pre-heating system for cold climate



ELECTRICAL SYSTEM

Electric circuit with protected connections in all exposed areas
 Voltage12 V
 Battery100 Ah (860 CCA)
 Alternator95 A
 Electric starting3.2 kw



HYDRAULIC SYSTEM

The HydrauMind hydraulic system affords the operator very precise backhoe movements. This system is energy efficient and incorporates two different working modes: economy and constant power. The advanced hydraulic system includes the "speed up" function to increase the working speed of the front loader.

SystemHydrauMind
 TypeClosed-center Load Sensing System (CLSS) with economy/power selector switch (power mode is the default)
 Pump typeVariable displacement axial piston
 Pump control systemLoad sensing
 Main valve "Load Independent Flow Divider" LIFD modular type
 Max delivery165 ltr/min **43.6 gal/min**
 Working pressure245 bar **3,553 psi**



SERVICE REFILL CAPACITIES

Engine oil9 ltr **2.4 U.S. gal**
 Cooling system14 ltr **3.7 U.S. gal**
 Fuel tank150 ltr **39.6 U.S. gal**
 Hydraulic oil tank41 ltr **10.8 U.S. gal**
 Hydraulic oil system capacity97 ltr **25.6 U.S. gal**
 Front axle oil7.5 ltr **2.0 U.S. gal**
 Rear axle oil14.5 ltr **3.8 U.S. gal**
 Gearbox oil, Power Shuttle20.2 ltr **5.3 U.S. gal**
 Gearbox oil, Power Shift28.0 ltr **7.4 U.S. gal**



STEERING

The front steering wheels are controlled by a hydrostatic load sensing steering priority valve system.
 Minimum turning radius at the outer edge of front tire:
 Without brakes4000 mm **13'1"**
 With brakes3400 mm **11'2"**



TRANSMISSION

WB156-5
 Shifting between 2WD and 4WD is achieved through an electro-hydraulic system. The transmission is operated through a torque converter and a power shift reversing shuttle; the mechanical 4-speed gearbox is synchronized

| Travel Speeds | 1st | | 2nd | | 3rd | | 4th | |
|----------------|------|------------|------|------------|------|-------------|------|-------------|
| | km/h | mph | km/h | mph | km/h | mph | km/h | mph |
| Forward | 6.3 | 3.9 | 11.4 | 7.1 | 21.3 | 13.2 | 37.8 | 23.5 |
| Reverse | 6.3 | 3.9 | 11.4 | 7.1 | 21.3 | 13.2 | 37.8 | 23.5 |

WB156PS-5

Electronically-controlled, four-wheel drive, full powershift transmission. Twist Grip or EGMT™ (Electronic Gear Management) gear controls for changing driving direction and gears at full power without disengaging the drive. Twist Grip Controls in manual mode.

| Travel Speeds | 1st | | 2nd | | 3rd | | 4th | |
|----------------|------|------------|------|------------|------|-------------|------|-------------|
| | km/h | mph | km/h | mph | km/h | mph | km/h | mph |
| Forward | 6.5 | 4.0 | 12.0 | 7.5 | 23.0 | 14.3 | 40.0 | 24.9 |
| Reverse | 6.5 | 4.0 | 12.0 | 7.5 | 23.0 | 14.3 | — | — |



AXLES

Heavy duty axles with planetary reduction gears in the wheel hubs. Front axle total oscillation angle is 20°. Differential lock in the rear axle controlled by electro-hydraulic system with a switch on loader lever.

Maximum front strength (Dynamic)9800 daN **22,031 lb**
 Maximum front strength (Static)23750 daN **53,392 lb**
 Maximum rear strength (Dynamic)7500 daN **16,861 lb**
 Maximum rear strength (static)18750 daN **42,152 lb**



BRAKES

Oil immersed disc brakes are actuated by individual braking on each rear wheel with two separate pedals. Total integral braking on the 4 wheels is activated by operating the two pedals at the same time.
 Disc diameter300 mm **11.8"**



CAB

ROPS (ISO 9249, SAE J1040) and FOPS (ISO 3449, SAE J231) Cab designed to offer the best visibility, ergonomics, low noise, and operator comfort. Two doors, full opening rear window with front and rear windshield wipers. Interior features include a fully adjustable seat, fresh filtered air intake ventilation, and easy to reach front and side dash boards.



LOADER

The design of the front loader allows for better tensile strength distribution and parallel movements when raising and lowering the bucket. Due to the linkage geometry, the number of greasing points has been dramatically reduced.

| | | |
|------------------------------------|----------------------|----------------------------|
| Standard bucket width | .2356 m | 7'9" |
| Standard bucket capacity (SAE) | .0.95 m ³ | 1.25 yd³ |
| Standard bucket weight | .454 kg | 1,000 lb |
| Lifting capacity at maximum height | .3900 kg | 8,598 lb |
| Lifting capacity at ground level | .5000 kg | 11,020 lb |
| Breakout force | .6000 kg | 13,224 lb |



BACKHOE

The boom has a rounded profile and reinforced structure built with cast ends allowing for 180° rotation while maintaining high rotation torque.

| | | |
|----------------------------------|----------|------------------|
| Bucket breakout force (ISO 6015) | .5936 kg | 13,087 lb |
| Arm breakout force (ISO 6015) | .3915 kg | 8,631 lb |

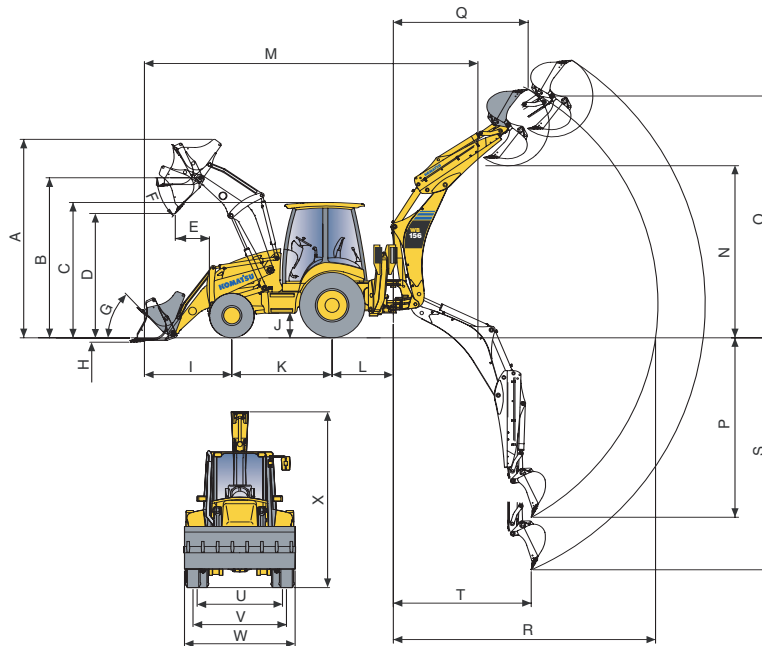

| | | | |
|---|--|---------|---------------|
| A | Maximum height | 4230 mm | 13'11" |
| B | Hinge pin height | 3367 mm | 11'1" |
| C | Overall height, ROPS Cab | 2935 mm | 9'8" |
| D | Maximum dumping height | 2622 mm | 8'7" |
| E | Reach at maximum height and 45° dump angle | 750 mm | 2'5" |
| F | Dumping angle | 45° | |
| G | Rollback angle | 45° | |
| H | Digging depth | 138 mm | 5.4" |
| I | Bucket reach (transport) | 2023 mm | 6'8" |
| J | Ground clearance | 430 mm | 1'5" |
| K | Wheel base | 2175 mm | 7'2" |
| L | Backhoe swing center distance | 1175 mm | 3'10" |
| M | Transportation length | 7504 mm | 24'7" |
| N | Dumping height (SAE) | 3761 mm | 12'4" |
| | - with retracted telescopic | 3747 mm | 12'4" |
| | - with extended telescopic | 4435 mm | 14'7" |

| | | | |
|---|---------------------------------|---------|---------------|
| O | Maximum digging height | 5525 mm | 18'2" |
| | - with extended telescopic | 6136 mm | 20'2" |
| P | Digging depth (2' level bottom) | 4670 mm | 15'4" |
| | - with extended telescopic | 5916 mm | 19'5" |
| Q | Reach at maximum height | 3046 mm | 10'0" |
| | - with extended telescopic | 4239 mm | 13'11" |
| R | Maximum reach from swing center | 6034 mm | 19'10" |
| | - with extended telescopic | 7164 mm | 23'6" |
| S | Maximum digging depth | 4725 mm | 15'6" |
| | - with extended telescopic | 5970 mm | 19'7" |
| T | Digging reach | 2320 mm | 7'7" |
| U | Rear tread | 1800 mm | 5'11" |
| V | Front tread | 1874 mm | 6'2" |
| W | Overall width (with bucket) | 2356 mm | 7'9" |
| X | Backhoe transportation height | 3676 mm | 12'1" |
| | - with telescopic arm | 3746 mm | 12'4" |



LIFTING CAPACITY

Standard Arm

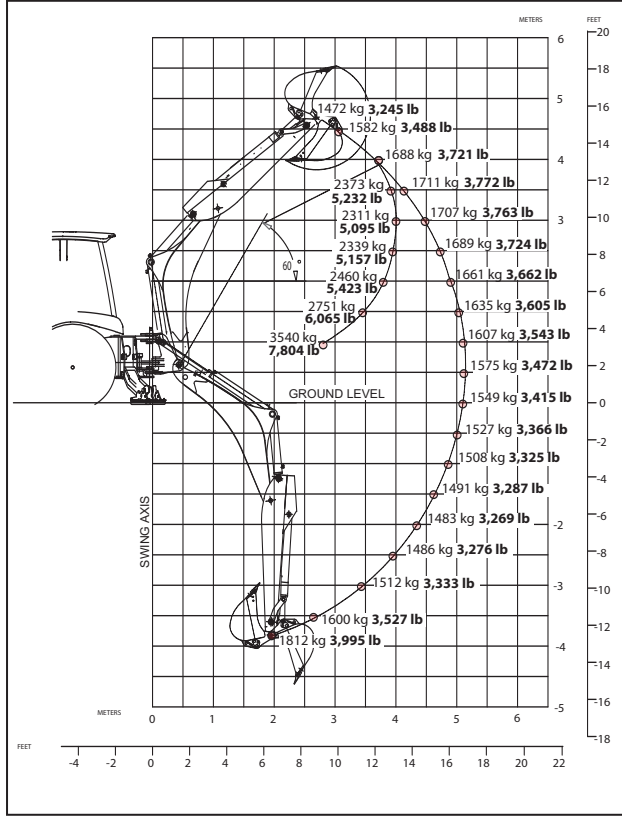

Retracted Telescopic Arm

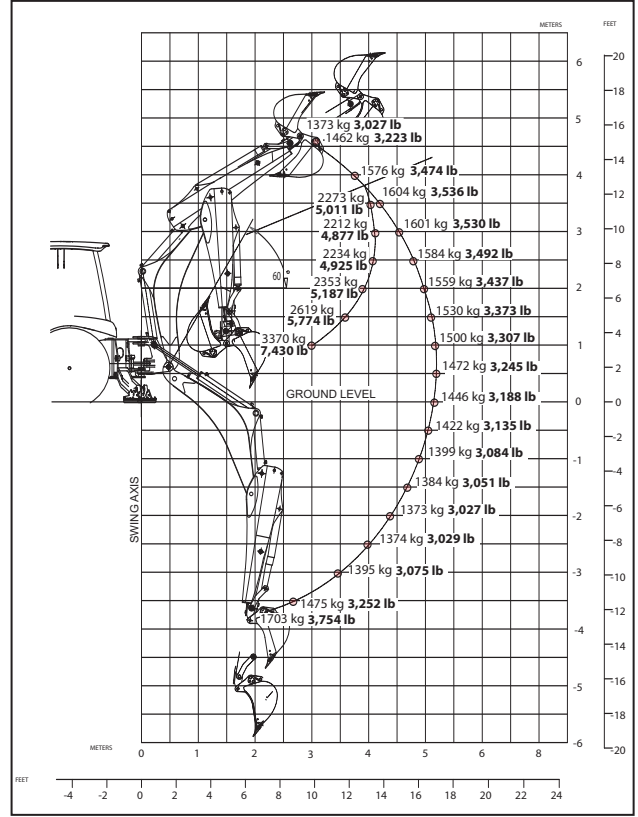

Extended Telescopic Arm

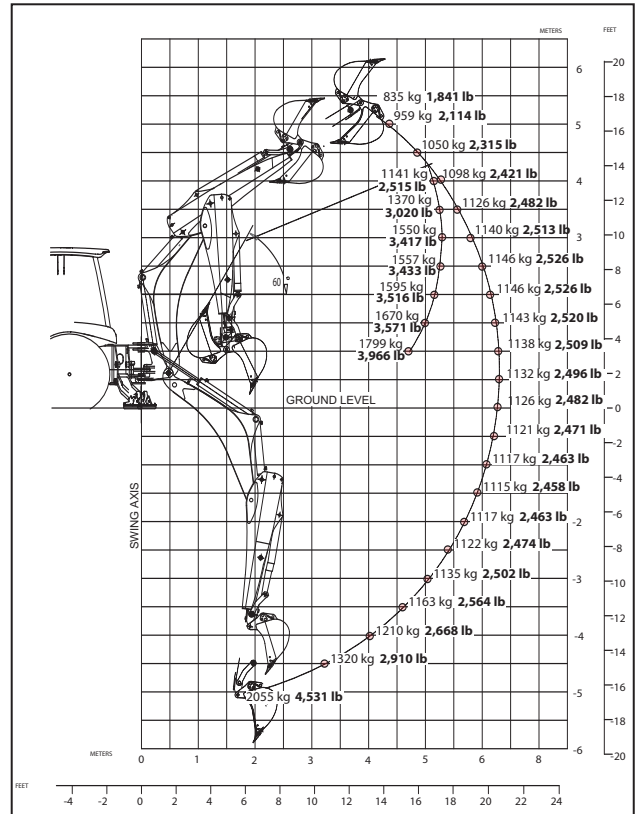



STANDARD EQUIPMENT

- Alarm, backup
- Anti-burst/anti-drift valves (outriggers)
- Backhoe, center mount
- Backhoe controls, excavator type
- Battery disconnect switch
- Boom transport & swing lock
- Brakes, wet-disc with dual pedals and lock (4 wheel braking in 4th gear only)
- Cast nose guard/counterweight
- Coat hook (cab only)
- Cup holder (only for a cabin without air-conditioner)
- Differential lock (100% rear axle on demand)
- Drive shaft guard (4-wheel drive only)
- Exhaust in line with ROPS post
- External tool box
- Fan, suction, and fan guard
- Flexible type rear fenders
- Gauges: coolant temperature, fuel level, tachometer, hour meter
- Hydraulic oil cooler, side by side
- Indicators: air cleaner service, engine coolant temperature, engine oil pressure, torque converter oil temperature, 4 wheel drive, low fuel, brake oil level, warning direction indicator, parking brake engagement, brake oil level, differential lock, cold engine preheat, generator warning
- ISO control pattern for backhoe
- Key start/stop system with auxiliary position
- Lamp, overhead for instrument panel (cab only)
- Lift cylinder lock bar
- Lights, working (2 front, 2 rear)
- Loader return-to-dig and float feature
- Mechanical locks, loader control and backhoe control
- Mirror, interior
- Multi-function pilot actuated loader control lever (transmission disconnect, multi-purpose bucket controls, differential lock, loader speed up)
- O-ring face seal hose connections
- Park brake (automatically disengages transmission when activated)
- Powershift transmission (PS series & AWS only)
- Power shuttle transmission
- Power socket, 12V for a mobile phone (cab only)
- ROPS/FOPS cab with heater (42,320 BTU) and fan
- Seat belt, retractable, 76 mm 3" wide
- Seat, mechanical suspension with armrests
- Seat position safety switch
- Spin-on fuel, engine oil, hydraulic transmission oil filters and water separator
- Stabilizer pads, flip-over type
- Stop lights and tail lights
- Steering, hydrostatic, load sensing
- Storage compartment, internal
- Throttles, hand and foot
- Tilttable engine hood
- Transmission disconnect switch on gearshift lever
- Vandalism protection (canopy only)
- Warning horn, front, electric



OPTIONAL EQUIPMENT

- Air conditioner (31,400 BTU)
- Auxiliary hydraulics for hand hammers
- Backhoe auxiliary hydraulics for hydraulic hammers or other unidirectional flow work tool (120 l/min **31.7 gpm**)
- Cold area (-30°C -22°F) arrangement
- High ambient and high altitude package
- High/low beam lights (2 front)
- Hydraulic quick coupler, loader
- Lights, working (4 front, 4 rear)
- Loader auxiliary hydraulics, multi-purpose
- Load stabilizer system
- Outrigger cylinder guards
- Pre filter
- Rear view mirrors, exterior
- ROPS/FOPS canopy
- Windshield, front for canopy with a window washer



AVAILABLE ATTACHMENTS

- Couplers (front & rear)
- Buckets (range)
- Hydraulic breakers
- Brooms / sweeper
- Compaction plate — hydraulic
- Compaction wheels
- Auger drives



This specification sheet may contain attachments and optional equipment that are not available in your area. Please contact your local Komatsu distributor for those items you may require. Materials and specifications are subject to change without notice.

KUSS185-00

©2006 Komatsu Printed in USA

DK07(7.5M)C

07/06 (EV-1)

KOMATSU[®]