

# KOMATSU®

## WA900-3 with Tier 2 Engine

**NET HORSEPOWER**  
638 kW 856 HP @ 2050 rpm

**OPERATING WEIGHT**  
107200 - 107350 kg  
236,340 - 236,670 lb

**BUCKET CAPACITY**  
11.5 - 13.0 m<sup>3</sup> 15.0 - 17.0 yd<sup>3</sup>

**WA  
900**

W  
H  
E  
E  
L  
L  
O  
A  
D  
E  
R



Photos may include optional equipment



**NET HORSEPOWER**  
638 kW 856 HP @ 2050 rpm

**OPERATING WEIGHT**  
107200 - 107350 kg  
236,340 - 236,670 lb

**BUCKET CAPACITY**  
11.5 - 13.0 m<sup>3</sup> 15.0 - 17.0 yd<sup>3</sup>

## **Reliability**

- Reliable Komatsu designed and manufactured components
- Sturdy main frame
- Adjustment-free, fully hydraulic, wet disc brakes
- Hydraulic hoses use flat face O-ring seals
- Cathion electrodeposition process is used to apply primer paint
- Powder coating process is used to apply main structure paint
- Sealed DT connectors for electrical connections



Photo may include optional equipment.

## **Easy Maintenance**

- Simple checks
- Vehicle Health Monitoring System (VHMS) with Orbcomm
- Rear access stairs
- Auto greasing system

## PRODUCTIVITY AND FUEL ECONOMY FEATURES

### High Performance SAA12V140E-3 Engine

Electronic Heavy Duty Common Rail fuel injection system provides optimum combustion of fuel.

This system also provides fast throttle response to match the machine's powerful tractive effort and fast hydraulic response.

**Net: 638 kW 856 HP**

### Low Emission Engine

This engine is EPA Tier 2 emission certified without sacrificing power or machine productivity.

### Low Fuel Consumption

Low fuel consumption is achieved because of the low-noise, high-torque engine and the large-capacity torque converter with maximum efficiency in the low-speed range.

### Durable Buckets

Komatsu buckets are manufactured using high-tensile strength steel with replaceable welded wear plates for extended bucket life. Additional strength has been added to the bucket bottom corners, side edges, and spill guard ends for increased durability.

### Bucket capacities

13.0 m<sup>3</sup> 17.0 yd<sup>3</sup> Standard boom

11.5 m<sup>3</sup> 15.0 yd<sup>3</sup> High-lift boom

### Dual-Mode Active Working System

The machine is equipped with a two mode active working system. This system provides the most efficient hydraulic flow for your operation. The

active working switch has two modes: Powerful Loading or Normal Loading.

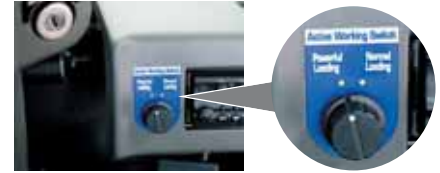

Dual modes switch

#### • Powerful Loading Mode:

Hydraulic flow to the work equipment is increased and reduced as required.

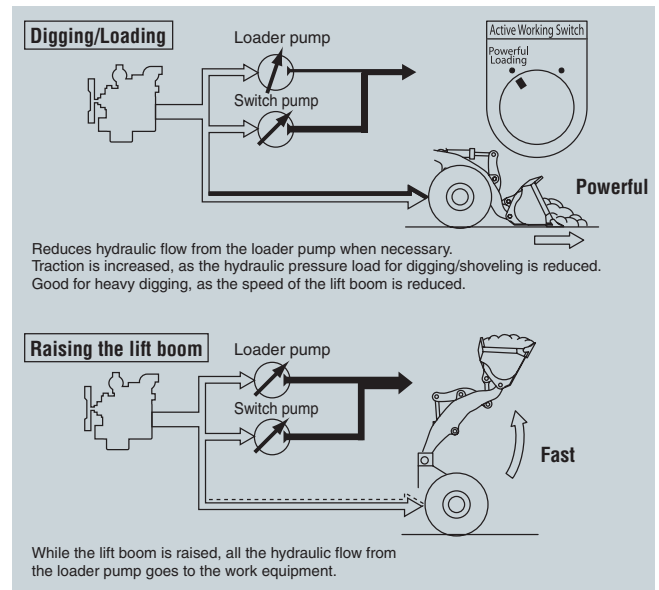

#### • Normal Loading Mode:

All hydraulic flow from the loader pump is transferred directly to the work equipment.

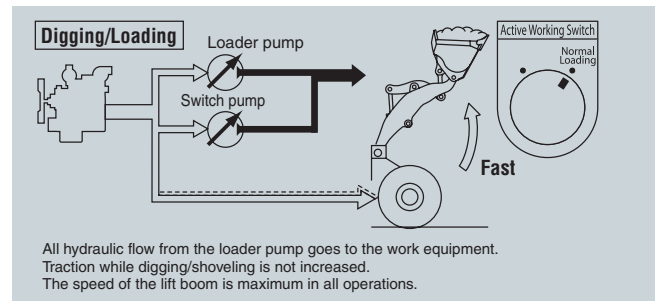



### Large Dumping Clearance

The WA900-3 was designed with ample dumping clearance for dump truck matching.

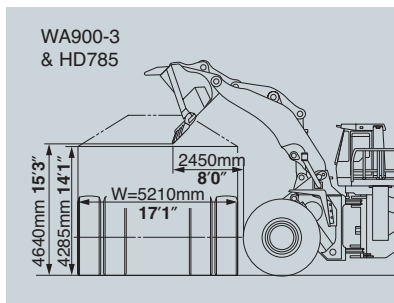

### High Breakout Force

Komatsu wheel loaders have high-tensile steel Z-bar loader linkages for maximum rigidity and maximum breakout force. Sealed loader linkage pins extend greasing intervals.

**67900 kg 149,690 lb** Breakout force  
13.0 m<sup>3</sup> 17.0 yd<sup>3</sup> spade nose bucket with teeth

### Excellent Stability

The WA900-3 has the widest tread in its class 3,350 mm 11'0" and a long 5,450 mm 17'11" wheelbase, for maximum machine stability.

### Static tipping load

(with 45/65-45, 58 PR (L-5) tires / bucket 13.0 m<sup>3</sup> 17.0 yd<sup>3</sup>)

**65670 kg 144,780 lb** Straight

**57430 kg 126,610 lb** 40° full turn

## RELIABILITY FEATURES

### Components

Komatsu manufactures the engine, torque converter, transmission, hydraulic units, and electric parts. Komatsu loaders are manufactured with an integrated production system under strict quality control.

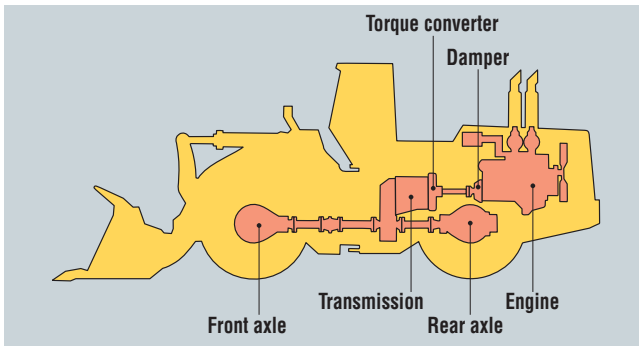

### Engine Pre-lube System

Durability of the engine is achieved by raising the engine oil pressure before starting the engine. When the operator turns the key, the pre-lubrication pump sends oil from the engine oil pan to the engine oil filter and raises the pressure of that oil to the set pressure. Then, the starting motor rotates to start the engine.

### Adjustment-Free Braking System

Wet multi-disc service brakes and fully hydraulic braking system mean lower maintenance costs and higher reliability. Wet disc brakes are fully sealed, helping keep contaminants out, reducing wear and maintenance. Brakes are adjustment-free, meaning even lower maintenance. Reliability is designed into the braking system by the use of two independent hydraulic circuits. This provides hydraulic backup should one of the circuits fail. Fully hydraulic brakes mean no air system to bleed, or the condensation of water in the system that can lead to contamination, corrosion, and freezing.

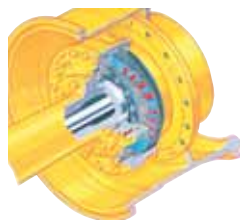

### High-rigidity Frames and Loader Linkage

The front and rear frames and the loader linkage have more torsional rigidity to secure resistance against increased stress. Frame and loader linkage are designed to accommodate actual working loads, and simulated computer testing proves its strength.

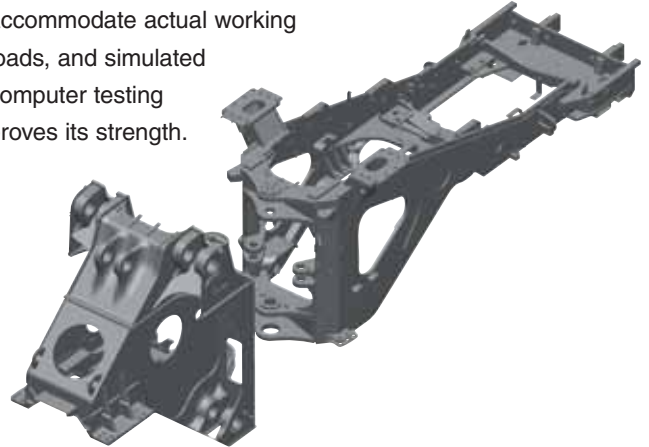

### Flat Face-to-Face O-Ring Seals

Flat face-to-face O-ring seals are used to securely seal hydraulic hose connections and to prevent oil leakage. In addition, buffer rings are installed to the head side of the hydraulic cylinders to lower the load on the rod seals and maximize reliability.

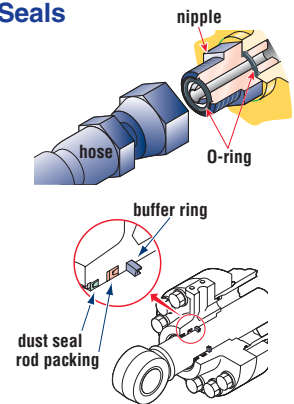

### Cathion Electrodeposition Primer Paint/ Powder Coating Final Paint

Cathion electrodeposition paint is applied as a primer paint and powder coating is applied as topcoat to the exterior sheet metal parts. This process results in a durable paint finish, even in the most severe environments. Some external parts are made of plastic providing long life and high impact resistance.

### Sealed DT Connectors

Main harnesses and controller connectors are equipped with sealed DT connectors providing high reliability, water resistance and dust resistance.



# MAINTENANCE FEATURES



Photo may include optional equipment.

## Simple Checks, Easy Maintenance

The main monitor and the maintenance monitor (EDIMOS II) are neatly arranged for a quick, clear reading of machine functions. The main monitor also has a diagnostic function.

### Main monitor



### Maintenance monitor



## Large Side Door

Right side door is easy to open and provides accessibility for maintenance.



## Rear Access Stairs

For the purpose of boarding and exiting the machine, rear access stairs with handrail are provided. The step width clearance and the step angle have been designed for easy entry and exit. A step light is provided for night boarding.



## Vehicle Health Monitoring System (VHMS)

VHMS is a management system for large equipment used in mining, which enables detailed monitoring of fleet via satellite communications. Komatsu and distributors can analyze “vehicle health” and other operating conditions and provide the information to the job site using the internet from a remote location on a near-real time basis.

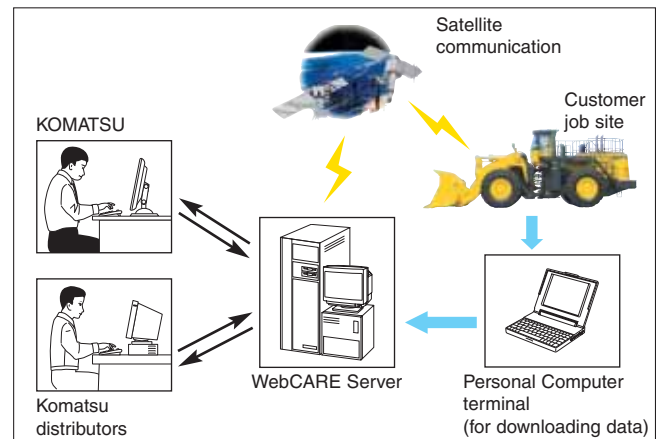

## Fuel Tank Cap with Mud Cover and Large Tool Box



Fuel tank cap



Tool box

## Auto-Greasing System

The periodic lubrication points, except for the drive shaft, are greased automatically according to a preset amount and interval. Quick-change grease canisters make replacement easy and clean.

# OPERATOR ENVIRONMENT

## Easy Operation

### Automatic Transmission with Electronically Controlled Modulation Valve (ECMV)

Automatic transmission with ECMV automatically selects the proper gear speed based on travel speed, engine speed, and other travel conditions. The ECMV system engages the clutch smoothly to prevent lags and shocks when shifting. This system provides efficient machine operation and a comfortable ride.

● **Kick-down switch:**

This valuable feature increases productivity. With the touch of a finger, the kick-down switch automatically downshifts from second to first when beginning the digging cycle. It automatically upshifts from first to second when the direction control lever is placed in reverse. This results in increased rim pull for better bucket penetration and reduced cycle times for higher productivity.

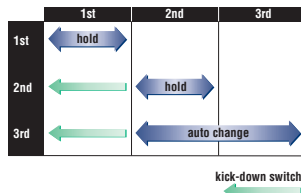

● **Hold switch:** If auto shift is selected and the operator activates this switch when the lever is at the 3rd gear speed position, the transmission is fixed to the current gear speed.

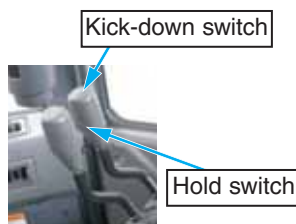

### Remote Boom Positioner

The highest and lowest position of the bucket can be set from the cab to match any truck body. Once the positioner is set, the bucket is smoothly stopped at desired position with no shock.



1: Remote boom positioner switch

### Variable Transmission Cut-off System

The operator can set the transmission cut-off pressure desired for the left brake pedal using the switch located on the right-side control panel. The operator can improve the working performance by setting the cut-off pressure to match working conditions.

- High cut-off pressure for digging operations.
- Low cut-off pressure for truck-loading operations.



2: T/M cut-off ON/OFF switch

3: T/M cut-off set switch

### Advanced Joystick Steering System (AJSS)

AJSS is a feedback steering system which has been incorporated to allow steering and forward and reverse selection to be controlled by wrist and finger control.

With the feedback function, the machine steering angle is exactly the same angle as the lever tilt angle.

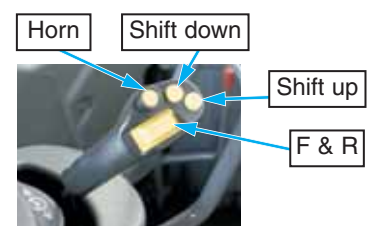

## Comfortable Operation

### Roomy, Quiet Cab With Power Windows

The cab is large, with a comfortably spacious interior and power windows. By adopting a high-capacity air conditioner, Komatsu ensures operator comfort, no matter the exterior conditions. Other features designed with operators in mind include a lunchbox storage space.



Lunchbox storage space

### Low Vibration & Noise

The cab rests on Komatsu viscous damping mounts (rubber and silicon oil) to reduce vibration and noise. All hydraulic equipment is mounted on high-resistance rubber to further reduce vibration and noise.



### Comfortable Operator's Seat

The operator's seat has a reclining/air suspension design with headrest to support the operator comfortably during long operation. Also, it is easy to adjust seat height with air suspension.



### Pillar-less Large Cab with ROPS / FOPS Level 2 Canopy

A wide pillar-less flat glass provides excellent front visibility. The wiper arm covers a large area to provide great visibility even on rainy days.



Rear heated glass provides clear view even in freezing or condensation conditions.





**DIMENSIONS**

Measured with 45/65-45, 58PR(L-5) tires

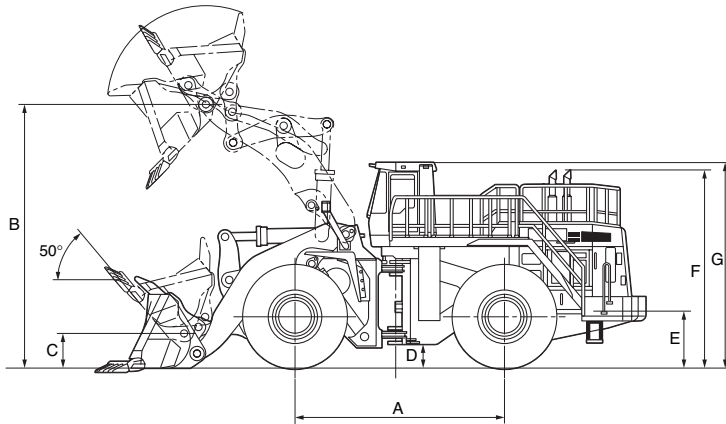

	Standard Boom	High lift Boom
Tread	3350 mm <b>11'0"</b>	
Width over tires	4585 mm <b>15'1"</b>	
A Wheelbase	5450 mm <b>17'11"</b>	
B Hinge pin height, max. height	6960 mm <b>22'10"</b>	7445 mm <b>24'5"</b>
C Hinge pin height, carry position	800 mm <b>2'7"</b>	
D Ground clearance	550 mm <b>1'10"</b>	
E Hitch height	1390 mm <b>4'7"</b>	
F Overall height, top of the stack	5130 mm <b>16'10"</b>	
G Overall height, ROPS cab	5275 mm <b>17'4"</b>	

	Standard Boom	High Lift Boom
	Excavating Bucket	Excavating Bucket
	Spade Nose Teeth	Spade Nose Teeth
Bucket capacity: heaped	13.0 m <sup>3</sup> <b>17.0 yd<sup>3</sup></b>	11.5 m <sup>3</sup> <b>15.0 yd<sup>3</sup></b>
struck	11.0 m <sup>3</sup> <b>14.4 yd<sup>3</sup></b>	9.7 m <sup>3</sup> <b>12.7 yd<sup>3</sup></b>
Bucket width	4810 mm <b>15'9"</b>	4810 mm <b>15'9"</b>
Bucket weight	12330 kg <b>27,180 lb</b>	11370 kg <b>25,070 lb</b>
Dumping clearance, max. height and 45° dump angle*	4640 mm <b>15'3"</b>	5255 mm <b>17'3"</b>
Reach at max. height and 45° dump angle*	2450 mm <b>8'0"</b>	2235 mm <b>7'4"</b>
Reach at 2130 mm (7') clearance and 45° dump angle*	3650 mm <b>12'0"</b>	4020 mm <b>13'2"</b>
Reach with arm horizontal and bucket level*	4640 mm <b>15'3"</b>	4760 mm <b>15'7"</b>
Operating height (fully raised)	9680 mm <b>31'9"</b>	9875 mm <b>32'5"</b>
Overall length (bucket on ground)*	14490 mm <b>47'6"</b>	14685 mm <b>48'2"</b>
Loader clearance circle (bucket at carry, outside corner of bucket)	22000 mm <b>72'2"</b>	22200 mm <b>72'10"</b>
Digging depth: 0°	165 mm <b>6.5"</b>	160 mm <b>6.3"</b>
10°	645 mm <b>2'1"</b>	610 mm <b>2'0"</b>
Static tipping load: straight	65670 kg <b>144,780 lb</b>	62540 kg <b>137,880 lb</b>
40° full turn	57430 kg <b>126,610 lb</b>	55030 kg <b>121,320 lb</b>
Breakout force	666 kN 67900 kgf <b>149,690 lb</b>	703 kN 71700 kgf <b>158,070 lb</b>
Operating weight	107200 kg <b>236,340 lb</b>	107350 kg <b>236,670 lb</b>

\* At the end of tooth

All dimensions, weights, and performance values based on SAE J732c and J742b standards.

Static tipping load and operating weight shown include lubricant, coolant, full fuel tank, ROPS canopy, cab, air conditioner, bucket and operator. Machine stability and operating weight are affected by counterweight, or ballast, tire size, and other attachments. Use either counterweight or ballast, not both. Apply the following weight changes to operating weight and static tipping load.



## STANDARD EQUIPMENT

- 2-spool valve for boom and bucket controls
- AM/FM stereo radio cassette
- Advanced Joystick Steering System (AJSS)
- Alternator, 90 A/24 V
- Air conditioner
- Ashtray and cigarette lighter
- Automatic greasing
- Automatic transmission F3 / R3
- Back-up alarm
- Back-up lamp
- Batteries, 160 Ah/12 V x 4
- Boom kick-out
- Bucket positioner
- Cab including front and rear wipers, windshield washers, and power windows
- Counterweight
- Directional signal
- Emergency brake
- Engine, Komatsu SAA12V140E-3 diesel
- Fast fill fuel system
- Fire extinguisher
- Floormat
- Front working lights (2)
- Hard water area arrangement (corrosion resister)
- Head lights (2)
- Heater and defroster
- Lift cylinders and bucket cylinder
- Radiator mask, lattice type
- Rear access stairs
- Rear defroster (electric)
- Rearview mirrors
- Rear working lights (2)
- Room mirror
- ROPS/FOPS Level 2 canopy
- Seat belt, 76 mm 3" wide retractable
- Seat, air suspension type with reclining
- Secondary steering
- Service brakes, wet disc type
- Side working lights (2)
- Standard boom
- Starting motor, 7.5 kW/24 V x 2
- Sun visor
- Vandalism protection
- Vehicle Health Monitoring System (VHMS) w/Orbcomm
- Water separator



## OPTIONAL EQUIPMENT

- Counterweight for high lift boom
- High lift boom
- Power train guard
- Rear under view mirror
- Sweeper wing

**KOMATSU**<sup>®</sup>