

KOMATSU®

WA200PT-5

NET HORSEPOWER
89 kW **119 HP** @ 2000 rpm

OPERATING WEIGHT
10289 - 10616 kg
22,683 - 23,404 lb

BUCKET CAPACITY
1.9 - 2.1 m³ **2.5 - 2.75 yd³**

WA
200
PT



Photos may include optional equipment.

PARALLEL TOOL
CARRIER

GALEO

WALK-AROUND

Komatsu-integrated design offers the best value, reliability, and versatility. Hydraulics, powertrain, frame, and all other major components are engineered by Komatsu. You get a machine whose components are designed to work together for higher production, greater reliability, and more versatility.

Reduced operator noise
to 70 dB(A)

Expanded main monitor
and troubleshooting display

Larger cab
with new layout design

New Tilt steering column

4 Piece sealing with buffer ring in hydraulic cylinders

Multi-function mono lever
with integrated F/R switch

New Parallel Lift Linkage

Large breakout force

Extended service intervals

Maintenance-free fully hydraulic wet multi-disc service and mechanical wet multi-disc parking brakes

Electronically controlled Hydrostatic Transmission (HST) with variable shift control system

Traction control system



NET HORSEPOWER
89 kW 119 HP @ 2000 rpm

OPERATING WEIGHT
10289 - 10616 kg
22,683 - 23,404 lb

BUCKET CAPACITY
1.9 - 2.1 m³
2.5 - 2.75 yd³

Powerful yet efficient Komatsu SAA6D102E-2 engine is Tier 2 EPA, EU, and Japan emissions certified

Full side opening
gull-wing engine doors

Radial Sealed
air cleaner

Swing-out hydraulic
radiator fan



Side-by-side type coolers
for easy access and cleaning

Overrun protection system

Ground level servicing
and fluid checks

Extremely low
fuel consumption

Photos may include optional equipment.

Flat face "O-Ring" Hydraulic Seals
for extended life

Staircase-type steps
with large rear-hinged doors

Sealed DT electrical connectors



Komatsu's highly productive, innovative technology, environmentally friendly machines built for the 21st century.

PRODUCTIVITY FEATURES

High Productivity and Low Fuel Consumption

Powerful Engine

A powerful SAA6D102E-2 turbocharged air-to-air aftercooled diesel engine provides an output of 89 kW **119 HP** for the WA200PT-5. This engine is Tier 2 EPA, EU, and Japan emissions certified without sacrificing power or machine productivity.

Low Fuel Consumption

The fuel consumption is reduced up to 15% due to the high-torque engine and Hydrostatic Transmission (HST) with maximum efficiency in the low-speed range.

Electronically-Controlled HST Using a 1-Pump, 2-Motor System

- The 1-pump, 2-motor system allows for high-efficiency and high tractive effort. Engine power is transmitted hydraulically to a transfer case, then manually out to the differentials and out to the four driving wheels.
- HST provides quick travel response and aggressive drive into the pile. The variable displacement system automatically adjusts to the tractive effort demand to provide maximum power and efficiency.
- Full auto-shifting eliminates any gear shifting and kick-down operation to allow the operator to concentrate on digging and loading.

- When high drive torque is needed for digging, climbing or initiating movement, the pump feeds both motors. This combination makes the loader very aggressive and quick.
- Under deceleration, the HST system acts as a dynamic brake on the mechanical drive system. The dynamic brake can hold the loader in position on most workable slopes. This can be an advantage in stockpiling and ramp loading.
- As the machine moves and gains ground speed, the torque demand decreases and the low speed motor is effectively removed from the drive system by a clutch. At this point, the flow is going to the high-speed motor and the low-speed motor is not causing a drag on the system.
- An inching pedal provides excellent simultaneous control of travel and equipment hydraulic speeds. By depressing the inching pedal, drive pump flow to the motors will decrease, reducing ground speed and allowing the operator to use the accelerator to increase flow to the equipment hydraulics. Depressing the inching pedal further will activate the service brakes.

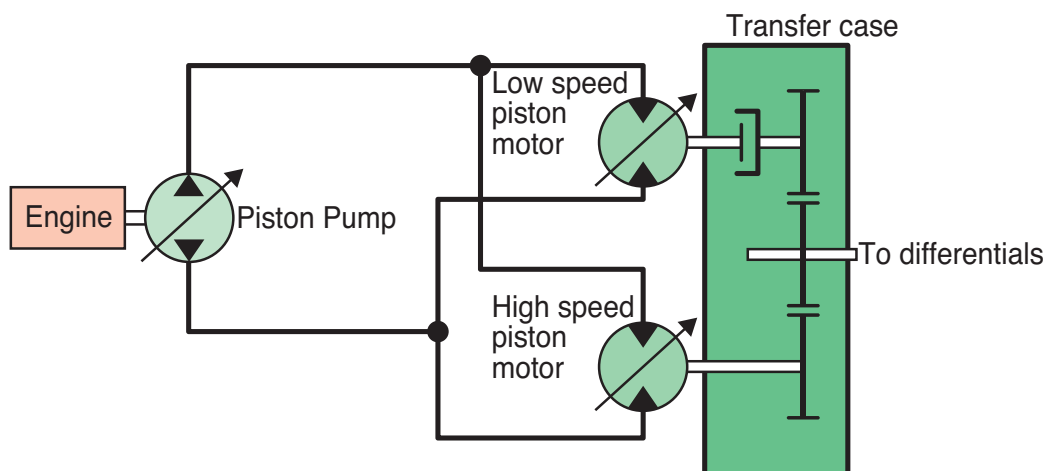

Electronically-Controlled HST with Variable Shift Control System

The operator can choose between four speed settings by dialing the speed range selector switch.

For V-cycles, the operator can set the speed control switch to 1 or 2, which provides aggressive digging, quick response, and fast hydraulics. For load and carry, select 3 or 4, which still provides aggressive digging but with much faster travel speed.



The variable shift switch allows the operator to adjust machine speed in confined V-loading applications. When in 1, the operator can adjust travel speed using the variable shift switch to match machine speed and hydraulics to the travel distance. This feature will also be an advantage when powering a broom.

Traction Control System

The traction control system reduces tire slippage in limited traction situations (such as sandy or wet surface operations). Placing the traction control switch in the "ON" position automatically reduces tire slippage by limiting the maximum amount of tractive effort to 50%. Traction control will be an

advantage in certain applications such as transfer stations where the loader may be working on slippery concrete. The traction control operates in 2nd, 3rd, and 4th speed.

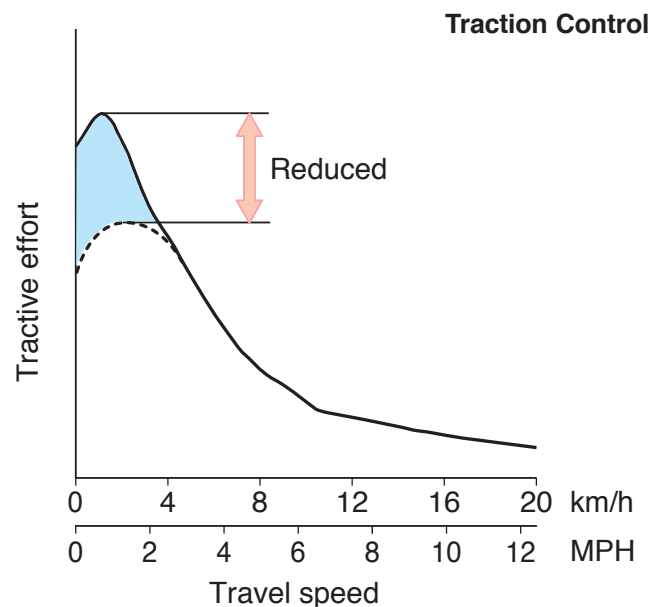
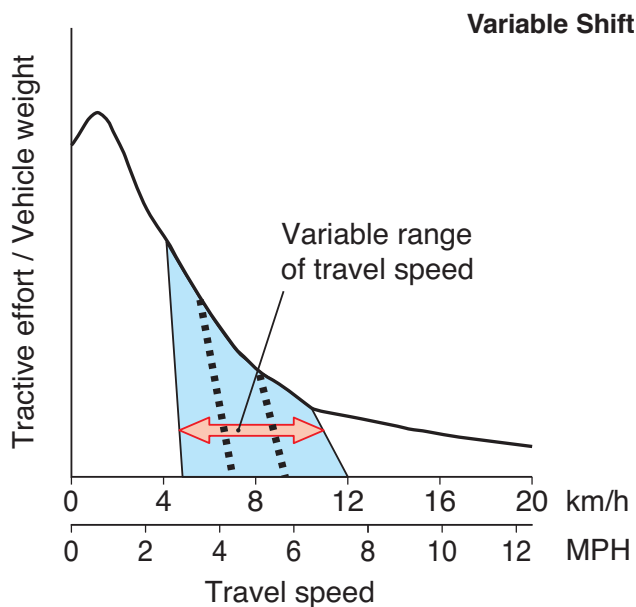

INCREASED RELIABILITY AND SERVICEABILITY

Main Monitor - EMMS (Equipment Management Monitoring System)

Komatsu's new main monitor keeps the operator informed of all machine functions at a glance. The monitor is located behind the steering wheel and displays 28 different machine functions including fluid/filter change intervals and troubleshooting memory display functions. The main gauges are analog type for easy viewing and other functions utilize light symbols or LCD readouts.



Swing-Out Cooling Fan

The new Komatsu cooling system is isolated from the engine to provide more efficient cooling and low noise. The swing-out hydraulic fan allows the operator to quickly clean out the cooling system.



The radiator, air-to-air cooler, and oil cooler are mounted side-by-side for more efficient cooling and easy cleaning. A fully-opening, gas spring assisted rear grill gives the operator excellent access to the swing-out fan and coolers.

Full Side-Opening Gull-Wing Engine Doors

Ground level engine service and daily service checks are made easy with the gas spring assisted full side opening gull-wing doors.



Extended Service Interval

Extended engine oil service interval:

250 H → 500 H

Extended drive shaft greasing interval:

1,000 H → 4,000 H



Overrun Prevention System

When the machine descends a slope of six degrees or less, maximum travel speed is automatically restricted to approximately 38 km/h **24 MPH**, for safety protection against damage of power train components and brakes by sensing the travel speed and controlling the discharge amount of the HST pump and motor. When the machine descends a steep slope and the travel speed reaches 36 km/h **24 MPH**, the caution lamp lights up to inform the operator to reduce the travel speed.

Note: When the machine descends a steep slope, the use of the service brake is necessary to limit travel speed.

Fully Hydraulic Wet Multi-Disc Service Brakes

The dual wet disc brakes at each wheel are fully sealed and adjustment free to reduce contamination wear and maintenance. The result is lower maintenance costs and higher reliability.

Added dependability is designed into the braking system by the use of two independent hydraulic circuits, providing hydraulic backup should one of the circuits fail.

If the brake oil pressure drops, the warning lamp flashes and the warning buzzer sounds intermittently.

The parking brake is also wet multi-disc (it is fully sealed and adjustment free), acting on the output shafts of the transfer case. The parking brake is mechanically controlled by a lever in the cab.

Parking Brake

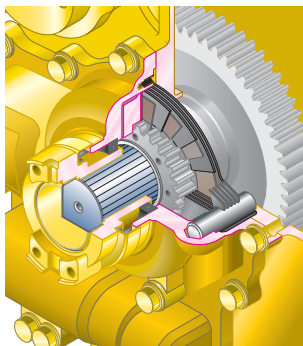

Service Brakes

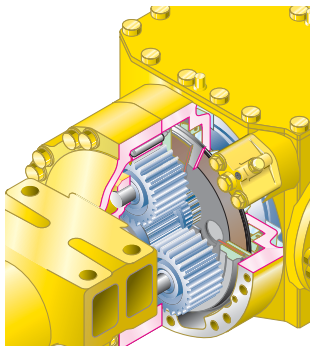

High-Rigidity Frames

The front and rear frames along with the loader linkage have high rigidity to withstand repeated twisting and bending loads to the loader body and linkage. Both the upper and lower center pivot bearings use tapered roller bearings for increased durability. The structure is similar to those of large sized loaders and the reinforced loader linkage ensures high strength.

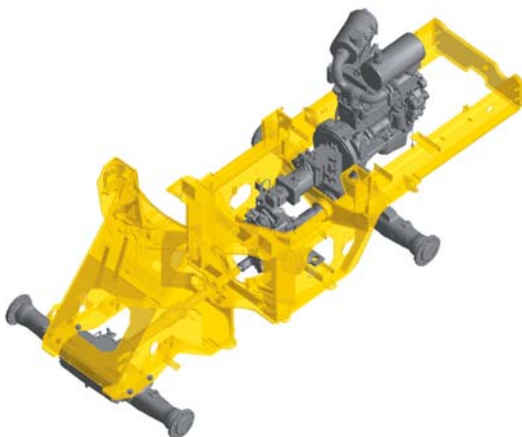

Flat Face-to-Face O-Ring Seals

Flat face-to-face O-ring seals are used to securely seal all hydraulic hose connections and to prevent oil leakage.

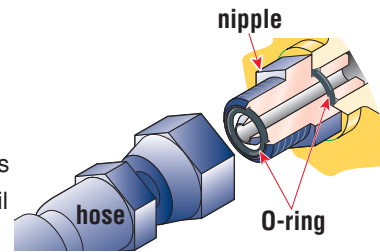

Cylinder Buffer Rings

Buffer rings are installed to the head-side of the hydraulic cylinders to lower the load on the rod seals, prolonging cylinder life by 30% and maximizing overall reliability.

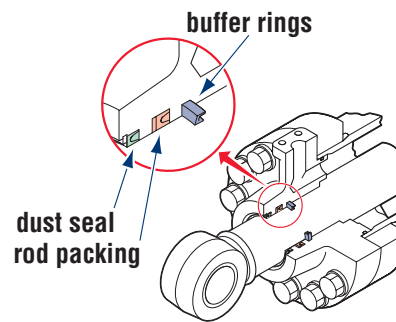

Cathion Electrodeposition Primer Paint/Powder Coating Final Paint

Cathion electrodeposition paint is applied as a primer paint and powder coating is applied as a topcoat to the exterior metal sheet parts. This process results in a durable rust-free machine, even in the most severe environments. Some external parts are made of plastic to provide long life and high impact resistance.

Sealed DT Connectors

Main harnesses and controller connectors are equipped with sealed DT connectors providing high reliability and dust and corrosion resistance.

Komatsu Powertrain Components

Komatsu manufactures the engine, transfer case, differentials, and electric parts on this wheel loader. Komatsu loaders are manufactured with an integrated production system under a strict quality control system.

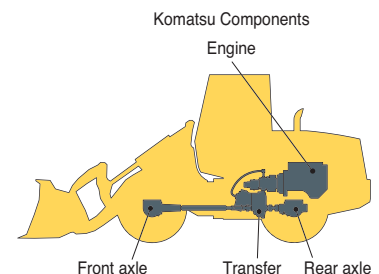

OPERATOR COMFORT

New Cab Layout

Komatsu's new cab layout provides the operator with a roomy, quiet, and efficient work environment. The low noise level inside the cab leads the industry at 70 dB(A) and loader controls are ergonomically designed to reduce operator fatigue and increase productivity.

Two Door Walk-Through Cab

Entry and exit into the new Komatsu cab starts with sloped staircase type steps and large diameter handrails for added safety and comfort. The large cab doors are rear-hinged to open 130 degrees offering easy entry/exit and will not hamper visibility when operating the machine with the doors latched open. A wide pillar-less flat glass windshield provides for excellent visibility. The wiper arm covers a large area to provide great visibility even on rainy days.



Low-Noise Design

Operator noise: 70 dB(A)

Dynamic noise (outside): 104 dB(A)

The large cab is mounted with Komatsu's unique ROPS/FOPS viscous mounts. The low-noise engine, hydraulically driven fan, and hydraulic pumps are mounted with rubber cushions, and the cab sealing is improved to provide a quiet, low-vibration, comfortable operating environment. Pressurization in the cab keeps dirt out further enhancing the operator's comfort.

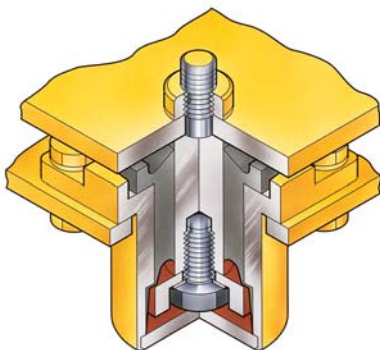

Multi-Function Loader Control Lever With Forward & Reverse Switch

A new multi-function control lever integrated with forward and reverse switch, allows the operator to easily operate the work equipment, to reduce operator fatigue, and to increase controllability. The adjustable wrist rest provides the operator with a variety of comfortable operating positions.



Electronically Controlled Directional Lever

The solid state electronic transmission shift control provides easy directional changes. The steering column mounted control lever can be operated without removing the operator's hand from the steering wheel, allowing improved comfort and control. The operator can use either the transmission directional control lever on the steering column or the transmission forward and reverse switch on the Multi-function Loader Control Lever.



Tilttable Steering Column

The operator can tilt the steering column for maximum comfort and control. The two-spoke steering wheel allows maximum visibility of the monitor panel and forward work environment.



WA200PT-5 PARALLEL TOOL CARRIER

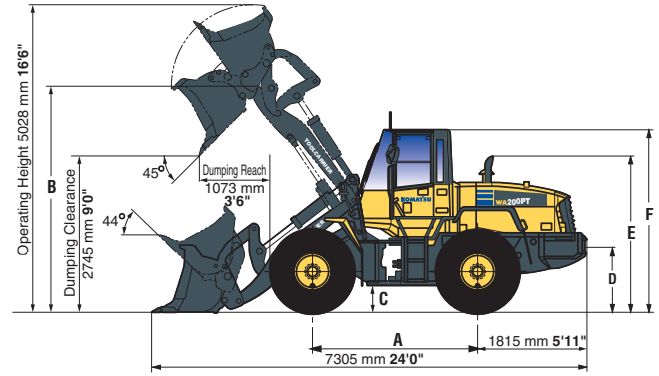
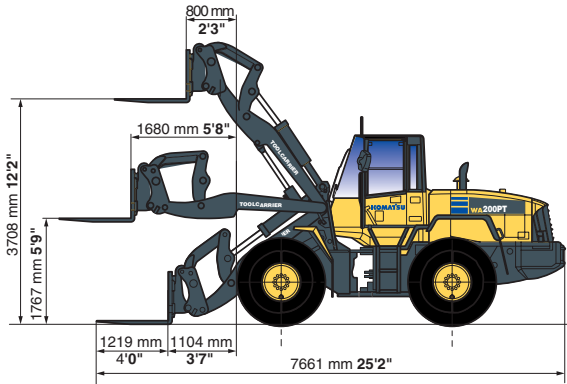

- Optional tire 20.5/25-12PR (L2)
- Tread 1930 mm 6'4"
- Width over tires 2492 mm 8'2"
- A Wheelbase 2840 mm 9'4"
- B Hinge pin height, maximum height 3837 mm 12'7"

- C Ground clearance 495 mm 1'7"
- D Hitch height 940 mm 3'1"
- E Overall height, top of stack 2785 mm 9'2"
- F Overall height, ROPS cab 3180 mm 10'5"

Fork

Static tipping load—boom level			
Fork level, 610 mm 24" load center	Straight	5902 kg	13,012 lb
	Full turn (40°)	4958 kg	10,930 lb
Operating weight		10289 kg	22,683 lb
Fork tine length		1219 mm	48"
Ground to top of tine at maximum lift		3708 mm	12'2"
Reach at maximum lift		800 mm	2'8"
Ground to top of tine—boom and tine level		1767 mm	5'9"
Reach boom and tine level		1680 mm	5'6"
Overall length—tine level on ground		7661 mm	25'2"
Operating load		2479 kg	5,465 lb

Operating load per SAE J1197 (Feb. 1991), 50% of static tipping load.

Static tipping load and operating weight shown include lubricants, coolant, full fuel tank, ROPS cab, 20.5/25-12PR (L2) tires, front fenders, and operator. Machine stability and operating weight are affected by counterweight, tire size, and other attachments. Note the following weight changes to operating weight and static tipping loads.

Weight Changes

	Change in Operating Weight		Change in Tipping Load				Width Over Tire		Ground Clearance		Change in Vertical Dimensions	
			Straight		Full Turn							
17.5/25-12PR (L2)	-450 kg	-992 lb	-323 kg	-529 lb	-271 kg	-485 lb	2413 mm	7'11"	425 mm	1'5"	-70 mm	-2.8"
17.5/25-12PR (L3)	-345 kg	-761 lb	-248 kg	-353 lb	-209 kg	-331 lb	2413 mm	7'11"	425 mm	1'5"	-70 mm	-2.8"
20.5/25-12PR (L2)	0 kg	0 lb	0 kg	0 lb	0 kg	0 lb	2492 mm	8'2"	495 mm	1'8"	0 mm	0"
20.5/25-12PR (L3)	+215 kg	+474 lb	+155 kg	+341 lb	+130 kg	+220 lb	2492 mm	8'2"	495 mm	1'8"	0 mm	0"
Install ROPS canopy (instead of cab)	-250 kg	-551 lb	-180 kg	-397 lb	-151 kg	-333 lb	N/A	N/A	N/A	N/A	N/A	N/A

Bucket

Bucket type with bolt-on cutting edge		Stockpile	
Bucket capacity	Heaped	1.9 m ³	2.5 yd³
	Struck	1.6 m ³	2.1 yd³
Bucket width		2550 mm	8'4"
Static tipping load	Straight	7644 kg	16,852 lb
	Full turn (40°)	6421 kg	14,155 lb
Operating weight		10616 kg	23,404
Bucket weight		937 kg	2,066 lb
Dumping clearance, maximum height and 45° dump angle		2745 mm	9'0"
Reach at 2130 mm 7' and 45° dump angle		1948 mm	6'4"
Reach with boom/bucket level		2505 mm	8'3"
Operating height fully raised		5098 mm	16'9"
Overall length	Bucket on ground	7305 mm	24'0"
	Bucket at carry	7223 mm	23'9"
Digging depth	0°	62 mm	2.4"
	10°	288 mm	0'11"
Breakout force		109 kN	24,581 lb

All dimensions, weights, and performance values based on SAE J-732c and J742b standards (bucket only).

DIMENSIONS

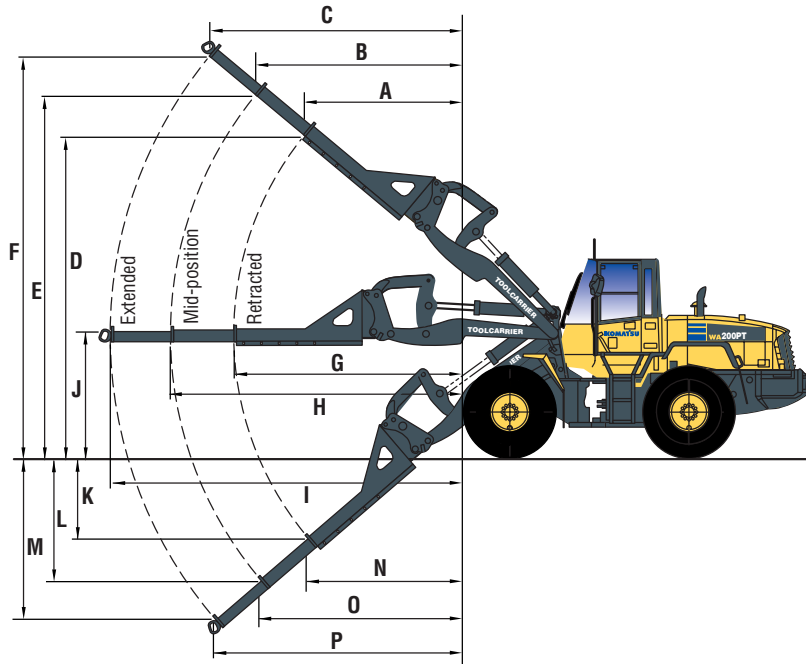

BUCKET SELECTION GUIDE

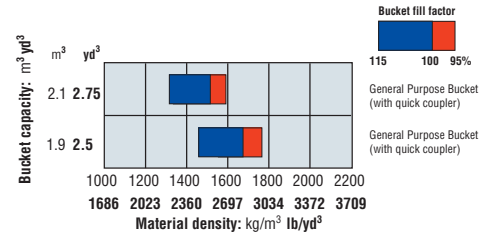

This guide, representing bucket sizes not necessarily manufactured by Komatsu, will help you select the proper bucket size for material density, loader configuration, and operating conditions. Optimum bucket size is determined after adding or subtracting all tipping load changes due to optional equipment. Bucket fill factors represent the approximate amount of material as a percent of rated bucket capacity. Fill factors are primarily affected by material, ground conditions, breakout force, bucket profile, and the cutting edge of the bucket used.

Material Handling Arm

Boom Position	Retracted		Mid-position		Extended	
Reach, fully raised	A	1945 mm 6'5"	B	2671 mm 8'9"	C	3156 mm 10'4"
Height, fully raised	D	5870 mm 19'3"	E	6751 mm 22'2"	F	7339 mm 24'1"
Maximum reach	G	3797 mm 12'5"	H	4939 mm 16'2"	I	5701 mm 18'8"
Height, maximum reach	J	1922 mm 6'4"	J	1922 mm 6'4"	J	1922 mm 6'4"
Depth, below ground	K	1570 mm 5'2"	L	2336 mm 7'8"	M	2848 mm 9'4"
Reach, below ground	N	2473 mm 8'1"	O	3319 mm 10'10"	P	3884 mm 12'9"
Operating load	1625 kg 3,582 lb		1299 kg 2,863 lb		1146 kg 2,526 lb	
Tipping load, straight	3869 kg 8,530 lb		3092 kg 6,816 lb		3100 kg 6,834 lb	
Tipping load, 40° full turn	3250 kg 7,165 lb		2597 kg 5,725 lb		2291 kg 5,050 lb	
Operating weight	10329 kg 22,771 lb		10329 kg 22,771 lb		10329 kg 22,771 lb	

Material (loose weight)	kg/m³	lb/yd³
Caliche	1250	2,100
Cinders	590	1,000
Clay and gravel, dry	1420	2,400
Clay and gravel, wet	1540	2,600
Clay, dry	1480	2,500
Clay, natural bed	1660	2,800
Clay, wet	1660	2,800
Coal, anthracite, broken	1100	1,850
Coal, bituminous, broken	830	1,400
Earth, dry, packed	1510	2,550
Earth, loam	1250	2,100
Earth, wet, excavated	1600	2,700
Granite, broken or large crushed	1660	2,800
Gravel, dry	1510	2,550
Gravel, dry 13 to 50 mm 1/2" to 2"	1690	2,850
Gravel, pit run (graveled sand)	1930	3,250
Gravel, wet 13 to 50 mm 1/2" to 2"	2020	3,400
Gypsum, crushed	1600	2,700
Limestone, broken or crushed	1540	2,600
Magnetite, iron ore	2790	4,700
Phosphate rock	1280	2,160
Pyrite, iron ore	2580	4,350
Sand and gravel, dry	1720	2,900
Sand and gravel, wet	2020	3,400
Sand, dry	1420	2,400
Sand, wet	1840	3,100
Sandstone, broken	1510	2,550
Shale	1250	2,100
Slag, broken	1750	2,950
Stone, crushed	1600	2,700
Topsoil	950	1,600

Versatile Work Equipment

Coupler system: The versatile, factory-supplied coupler system provides fast, efficient tool changes without leaving the cab. Your Komatsu tool carrier allows interchangeability between models as well as several major manufacturers. This design also allows superior visibility of the work equipment.

Full line of attachments: Ask your Komatsu distributor about the availability of work equipment for your particular job.





STANDARD EQUIPMENT

- Alternator, 60A, 24 volt
- Automatic boom kickout
- Axles, semi floating
- Back-up alarm
- Back-up light, rear
- Batteries, 110 Ah/2 x 12 V, 950 CCA
- Bucket positioner, automatic, 2 position
- Cab (ROPS/FOPS) with adjustable wrist rest, cigarette lighter/ash tray, dome light, electrically heated rear window, floor mat, front (intermittent) and rear wiper/washer, rear view mirrors (2 outside, 2 inside), right hand and left hand door access with steps, sun visor
- Counterweight, standard and additional
- Differentials, torque proportioning
- Dump speed, 2 mode select
- EMMS (Equipment Management Monitoring System)
 - Gauges, (Speedometer, engine water temperature, fuel level, HST oil temperature)
 - LCD displays, (filter/oil replacement time, HST selection, odometer, service meter, trouble shooting)
- Lights (Axle oil temperature, battery charge, brake oil pressure, central warning, directional indicator, engine oil pressure, engine pre-heater, HST oil filter clogging, high beam, maintenance, parking brake reminder, parking brake warning, radiator coolant level, steering oil pressure, transmission speed range, turn signals)
- Engine, Komatsu SAA6D102E-2
- Engine shut-off system, electric
- Fan, hydraulic driven, swing out
- Fenders, full front, partial rear
- Fuel water separator
- Horn, electric
- Hydraulic quick coupler
- Lift cylinders and bucket cylinder
- Lifting eyes
- Lights
 - Stop and tail
 - Turn signal (2 front, 2 rear)
 - Working (2 front, 2 rear, 2 outside cab)
- Loader linkage with standard lift boom
- Maintenance monitor panel
- Mono-lever loader control with transmission F/R switch
- Parking brake, wet disc
- Radiator mask, hinged
- Seat belt, retractable, 76 mm 3" wide
- Seat, cloth, suspension, reclining with armrests and headrest, and a document holder
- Service brakes, hydraulic, wet multi-disc, inboard
- Speedometer (mph)
- Starting aid, intake manifold preheater
- Starting motor, 4.5 kW/24 V
- Steering wheel, tilttable
- Tires 17.5/25-12PR (L2), tubeless and rims
- Transmission (Hydrostatic with speed range select), automatic
- Transmission control, electric, steering column/loader control lever selectable
- 3-spool valve with PPC; includes valve, lever and piping
- Vandalism protection kit



OPTIONAL EQUIPMENT

- Air conditioner with heater/defroster/pressurizer
- Air ride seat
- Auxiliary steering
- ECSS (Electronically Controlled Suspension System)
- Fenders, rear full
- Heater and defroster
- JRB bucket, general purpose, for use with coupler with BOCE 1.9 m³ **2.5 yd³**
- JRB bucket, general purpose, for use with coupler with BOCE 2.1 m³ **2.75 yd³**
- JRB construction forks for use with coupler, 1219 mm **48"**
- JRB extendable boom, 3-section, for use with coupler
- JRB hydraulic quick coupler
- Limited-slip differential, front and rear
- Radio, AM/FM stereo with cassette
- Rims only, less tires
 - Fits 20.5/25, and 550/65 tires
- ROPS canopy
- Tires (bias ply)
 - 17.5/25-12PR (L3)
 - 20.5/25-12PR (L2)
 - 20.5/25-12PR (L3)
- Brand preference, Goodyear
- Tires (radial ply)
 - 17.5-R25 VKT (L2) Bridgestone
 - 17.5-R25 XTLA (L2) Michelin
 - 17.5-R25 XHA (L3) Michelin
 - 20.5-R25 VUT (L2) Bridgestone
 - 20.5-R25 XTLA (L2) Michelin
 - 20.5-R25 XHA (L3) Michelin
 - 20.5-R25 VMT (L3) Bridgestone
 - 550/65 R25 XTLA (L2) Michelin
 - 550/65 R25 XLD (L3) Michelin
- Vinyl seat

AESS652-01

©2004 Komatsu Printed in USA

DK09(5M) C (5M)C 05/06

09/04 (EV-2)

KOMATSU®

