

KOMATSU®

WA200-5

NET HORSEPOWER
89 kW **120 HP** @ 2000 rpm

OPERATING WEIGHT
9920 - 10375 kg
21,870 - 22,872 lb

BUCKET CAPACITY
1.7 - 2.4 m³ **2.2 - 3.1 yd³**

WA
200

W
H
E
E
L
L
O
A
D
E
R



Photos may include optional equipment.

WALK-AROUND

Komatsu-integrated design offers the best value, reliability, and versatility. Hydraulics, powertrain, frame, and all other major components are engineered by Komatsu. You get a machine whose components are designed to work together for higher production, greater reliability, and more versatility.

Reduced operator noise
to 70 dB(A)

Expanded main monitor
and troubleshooting display

Larger cab
with new layout design

New tilt steering column

4-Piece sealing with buffer ring in hydraulic cylinders

Multi-function mono lever
with integrated F/R switch

Extended service intervals

Large breakout force

Traction control system

Adjustment-free fully hydraulic wet multi-disc service brake and mechanical wet multi-disc parking brake

Electronically controlled Hydrostatic Transmission (HST) with variable shift control system



NET HORSEPOWER
89 kW 120 HP @ 2000 rpm

OPERATING WEIGHT
9920 - 10375 kg
21,870 - 22,872 lb

BUCKET CAPACITY
1.7 - 2.4 m³
2.2 - 3.1 yd³

Powerful yet efficient Komatsu
SAA6D102E-2 **engine**

Full side opening
gull-wing engine doors

Radial sealed
air cleaner

Swing-out hydraulic
radiator fan



Side-by-side type coolers
for easy access and cleaning

Overrun protection system

Ground level servicing
and fluid checks

Extremely low
fuel consumption

Photos may include optional equipment.

Staircase-type steps
with large rear-hinged doors

Flat face "O-Ring" hydraulic seals
for extended life

Sealed DT electrical connectors

PRODUCTIVITY FEATURES

High Productivity and Low Fuel Consumption

Powerful Engine

A powerful SAA6D102E-2 turbocharged air-to-air aftercooled diesel engine provides a net horsepower of 89 kW **120 HP** for the WA200-5.

Low Fuel Consumption

The fuel consumption is reduced up to 15% due to the high-torque engine and Hydrostatic Transmission (HST) with maximum efficiency in the low-speed range.

Electronically-Controlled HST Using a 1-Pump, 2-Motor System

- The 1-pump, 2-motor system allows for high-efficiency and high tractive effort. Engine power is transmitted hydraulically to a transfer case, then manually out to the differentials and out to the four driving wheels.
- HST provides quick travel response and aggressive drive into the pile. The variable displacement system automatically adjusts to the tractive effort demand to provide maximum power and efficiency.
- Full auto-shifting eliminates any gear shifting and kick-down operation to allow the operator to concentrate on digging and loading.
- When high drive torque is needed for digging, climbing or initiating movement, the pump feeds both motors. This combination makes the loader very aggressive and quick.
- Under deceleration, the HST system acts as a dynamic brake on the mechanical drive system. The dynamic brake can hold the loader in position on most workable slopes. This can be an advantage in stockpiling and ramp loading.
- As the machine moves and gains ground speed, the torque demand decreases and the low speed motor is effectively removed from the drive system by a clutch. At this point, the flow is going to the high-speed motor and the low-speed motor is not causing a drag on the system.
- An inching pedal provides excellent simultaneous control of travel and equipment hydraulic speeds. By depressing the inching pedal, drive pump flow to the motors will decrease, reducing ground speed and allowing the operator to use the accelerator to increase flow to the equipment hydraulics. Depressing the inching pedal further will activate the service brakes.

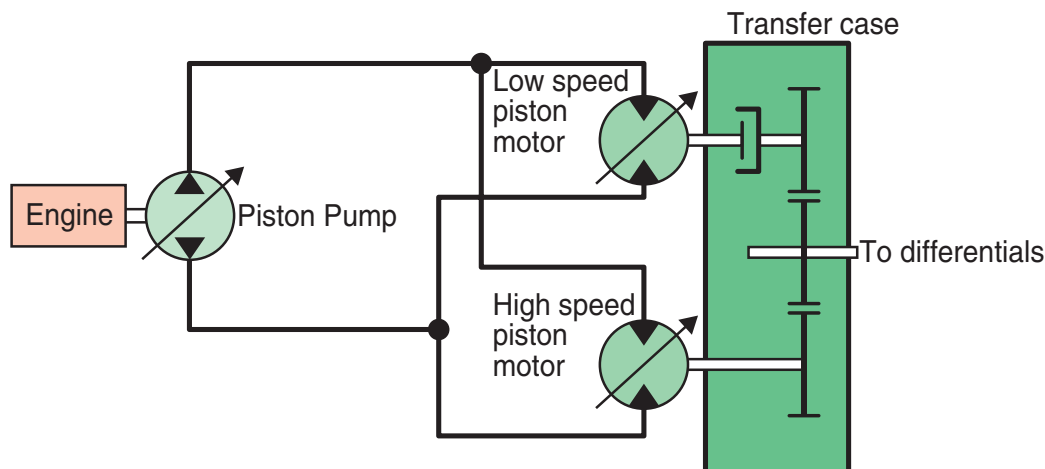

Electronically-Controlled HST with Variable Shift Control System

The operator can choose between four speed settings by dialing the speed range selector switch.

For V-cycles, the operator can set the speed control switch to 1 or 2, which provides aggressive digging, quick response and fast hydraulics. For load and carry, select 3 or 4 which still provides aggressive digging but with much faster travel speed.



The variable shift switch allows the operator to adjust machine speed in confined V-loading applications. When in 1, the operator can adjust travel speed using the variable shift switch to match machine speed and hydraulics to the travel distance. This feature will also be an advantage when powering a broom or snowblower.

Traction Control System

The traction control system reduces tire slippage in limited traction situations (such as sandy or wet surface operations). Placing the traction control switch in the “ON” position automatically reduces tire slippage by limiting the maximum amount of tractive effort to 50%. Traction control will be an advantage in certain applications such as transfer stations where the loader may be working on slippery concrete. The traction control operates in 2nd, 3rd and 4th speed.

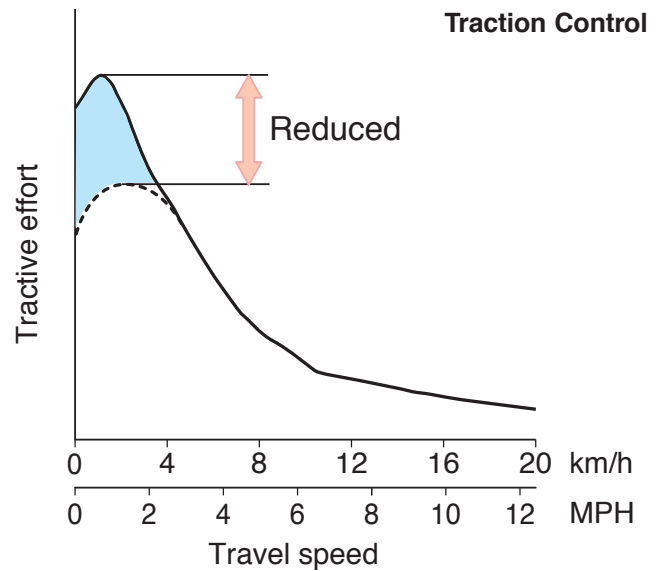
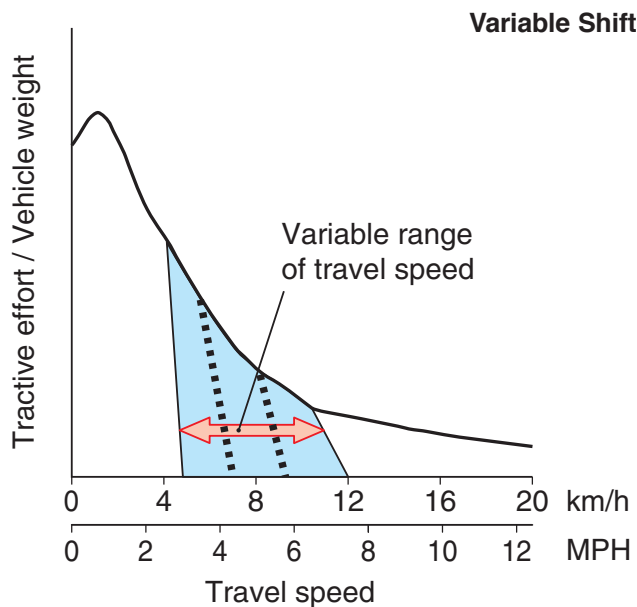

INCREASED RELIABILITY AND SERVICEABILITY

Main Monitor - EMMS (Equipment Management Monitoring System)

Komatsu's new main monitor keeps the operator informed of all machine functions at a glance. The monitor is located behind the steering wheel and displays 28 different machine functions including fluid/filter change intervals and troubleshooting memory display functions. The main gauges are analog type for easy viewing and other functions utilize light symbols or LCD readouts.



Swing-Out Cooling Fan

The new Komatsu cooling system is isolated from the engine to provide more efficient cooling and low noise. The swing-out hydraulic fan allows the operator to quickly clean out the cooling system.



The radiator, air-to-air cooler and oil cooler are mounted side-by-side for more efficient cooling and easy cleaning. A fully-opening, gas spring assisted rear grill gives the operator excellent access to the swing-out fan and coolers.

Full Side-Opening Gull-Wing Engine Doors

Ground level engine service and daily service checks are made easy with the gas spring assisted full side opening gull-wing doors.



Extended Service Interval

Extended engine oil service interval:

250 H → 500 H

Extended drive shaft greasing interval:

1,000 H → 4,000 H



Overrun Prevention System

When the machine descends a slope of six degrees or less, maximum travel speed is automatically restricted to approximately 38 km/h 24 MPH, for protection against damage of power train components and brakes by sensing the travel speed and controlling the discharge amount of the HST pump and motor. When the machine descends a steep slope and the travel speed reaches 36 km/h 24 MPH, the caution lamp lights up to inform the operator to reduce the travel speed.

Note: When the machine descends a steep slope, the use of the service brake is necessary to limit travel speed.

Fully Hydraulic Wet Multi-Disc Service Brakes

The dual wet disc brakes at each wheel are fully sealed and adjustment free to reduce contamination, wear and maintenance. The result is lower maintenance costs and higher reliability.

Added dependability is designed into the braking system by the use of two independent hydraulic circuits, providing hydraulic backup should one of the circuits fail.

If the brake oil pressure drops, the warning lamp flashes and the warning buzzer sounds intermittently.

The parking brake is also wet multi-disc (it is fully sealed and adjustment free), acting on the output shafts of the transfer case. The parking brake is mechanically controlled by a lever in the cab.

Parking Brake

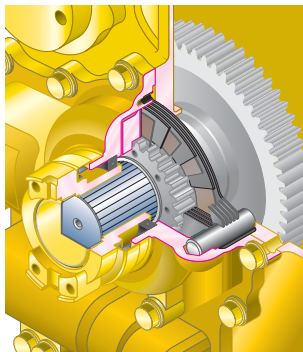

Service Brakes

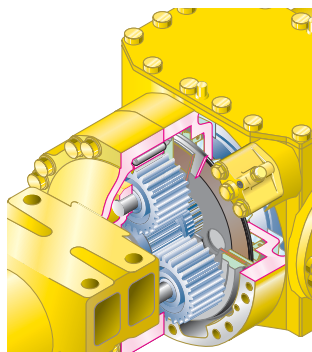

High-Rigidity Frames

The front and rear frames along with the loader linkage have high rigidity to withstand repeated twisting and bending loads to the loader body and linkage. Both the upper and lower center pivot bearings use tapered roller bearings for increased durability. The structure is similar to those of large sized loaders and the reinforced loader linkage ensures high strength.

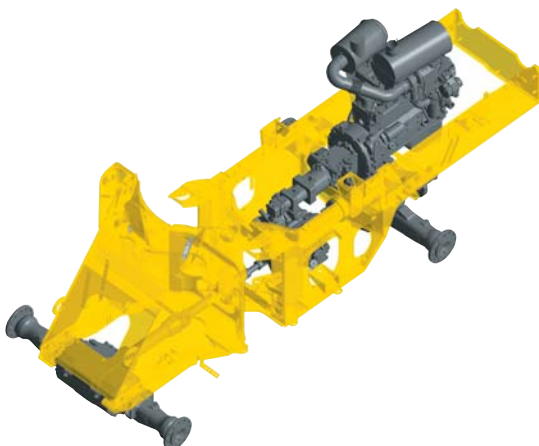

Flat Face-to-Face O-Ring Seals

Flat face-to-face O-ring seals are used to securely seal all hydraulic hose connections.

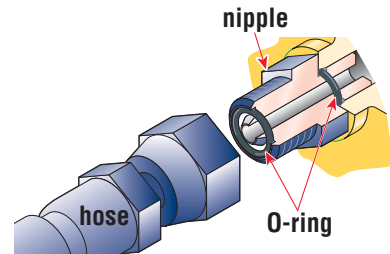

Cylinder Buffer Rings

Buffer rings are installed to the head-side of the hydraulic cylinders to lower the load on the rod seals, prolonging cylinder life by 30% and maximizing overall reliability.

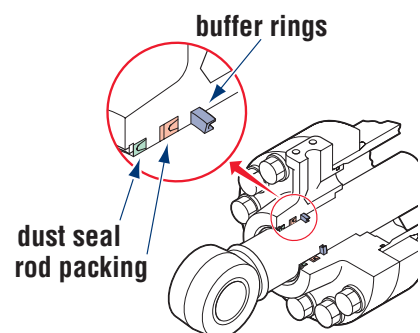

Cathion Electrodeposition Primer Paint/Powder Coating Final Paint

Cathion electrodeposition paint is applied as a primer paint and powder coating is applied as a topcoat to the exterior metal sheet parts. This process results in a durable rust-free machine, even in the most severe environments. Some external parts are made of plastic to provide long life and high impact resistance.

Sealed DT Connectors

Main harnesses and controller connectors are equipped with sealed DT connectors providing high reliability and dust and corrosion resistance.

Komatsu Powertrain Components

Komatsu manufactures the engine, transfer case and differentials on this wheel loader. Komatsu loaders are manufactured with an integrated production system under a strict quality control system.

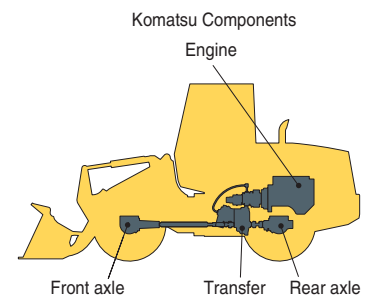

OPERATOR COMFORT

New Cab Layout

Komatsu's new cab layout provides the operator with a roomy, quiet and efficient work environment. The low noise level inside the cab leads the industry at 70 dB(A) and loader controls are ergonomically designed to reduce operator fatigue and increase productivity.

Two Door Walk-Through Cab

Entry and exit into the new Komatsu cab starts with sloped staircase type steps and large diameter handrails. The large cab doors are rear-hinged to open 130 degrees offering easy entry/exit and will not hamper visibility when operating the machine with the doors latched open. A wide pillar-less flat glass windshield provides for excellent visibility. The wiper arm covers a large area to provide great visibility even on rainy days.



Low-Noise Design

Operator noise: 70 dB(A)

Dynamic noise (outside): 104 dB(A)

The large cab is mounted with Komatsu's unique ROPS/FOPS viscous mounts. The low-noise engine, hydraulically driven fan, and hydraulic pumps are mounted with rubber cushions, and the cab sealing

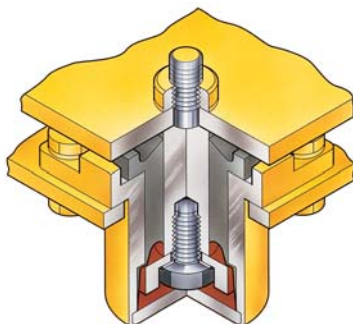

is improved to provide a quiet, low-vibration, and comfortable operating environment. Pressurization in the cab keeps dirt out further enhancing the operator's comfort.

Multi-Function Loader Control Lever With Forward & Reverse Switch

A new multi-function control lever integrated with forward and reverse switch allows the operator to easily operate the work equipment, to reduce operator fatigue and to increase controllability. The adjustable wrist rest provides the operator with a variety of comfortable operating positions.



Electronically Controlled Directional Lever

The solid state electronic transmission shift control provides easy directional changes. The steering column mounted control lever can be operated without removing the operator's hand from the steering wheel, allowing improved comfort and control. The operator can use either the transmission directional control lever on the steering column or the transmission forward and reverse switch on the Multi-function Loader Control Lever.



Tiltable Steering Column

The operator can tilt the steering column to allow maximum comfort and control. The two-spoke steering wheel allows maximum visibility of the monitor panel and forward work environment.

Comforts of Home

The large cab allows room for a large lunch box holder, a variety of cup holders and a hot/cold box storage area. Optional air conditioning and the optional AM/FM stereo cassette system create a comfortable and controlled work environment.



DIMENSIONS

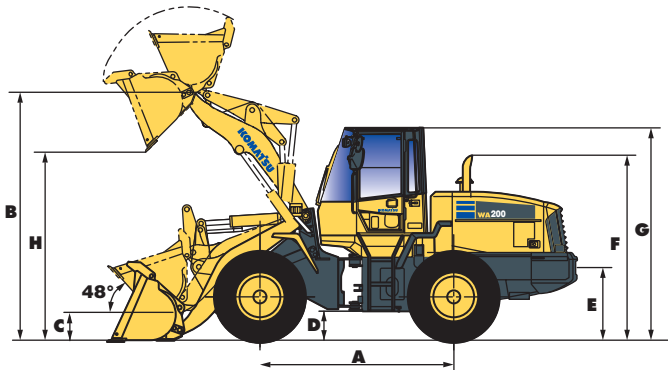

Tread	1930 mm	6'4"
Width over tires	2470 mm	8'1"
A Wheelbase	2840 mm	9'4"
B Hinge pin height at max. height	3705 mm	12'2"
C Hinge pin height at carry position	380 mm	1'3"
D Ground clearance	495 mm	1'8"
E Hitch height	940 mm	3'1"
F Overall height, top of stack	2785 mm	9'2"
G Overall height ROPS cab	3180 mm	10'5"
H See Dumping Clearance Below		

Measured with 20.5-25-12PR (L2) tires

Bucket		Stockpile Bucket With Bolt-On Cutting Edge		Excavating Bucket With Bolt-On Cutting Edge		Light Material Bucket With Bolt-On Cutting Edge	
Bucket capacity	Heaped	2.0 m ³	2.6 yd ³	1.7 m ³	2.2 yd ³	2.4 m ³	3.1 yd ³
	Struck	1.7 m ³	2.2 yd ³	1.4 m ³	1.8 yd ³	2.0 m ³	2.6 yd ³
Bucket width		2550 mm	8'4"	2550 mm	8'4"	2550 mm	8'4"
Bucket weight		785 kg	1,731 lb	740 kg	1,631 lb	875 kg	1,929 lb
Static tipping load	Straight	9290 kg	20,481 lb	9350 kg	20,614 lb	9140 kg	20,150 lb
	40° full turn	8080 kg	17,813 lb	8140 kg	17,945 lb	7955 kg	17,537 lb
Dumping clearance, maximum height and 45° dump angle (H)		2830 mm	9'3"	2885 mm	9'6"	2725 mm	8'11"
Reach at 2130 mm 7' 45° dump angle		1405 mm	4'7"	1380 mm	4'6"	1455 mm	4'9"
Reach at maximum height and 45° dump angle		925 mm	3'0"	870 mm	2'10"	1030 mm	3'5"
Reach with arm horizontal and bucket level		2140 mm	7'0"	2060 mm	6'9"	2290 mm	7'6"
Operating height fully raised		4955 mm	16'3"	4835 mm	15'10"	5065 mm	16'7"
Overall length	Bucket on Ground	6895 mm	22'7"	6825 mm	22'5"	7060 mm	23'2"
Turning radius		5650 mm	18'6"	5620 mm	18'5"	5715 mm	18'9"
Digging depth	0°	65 mm	2.5"	65 mm	2.5"	65 mm	2.5"
	10°	250 mm	9.8"	235 mm	9.2"	275 mm	10.8"
Breakout force		12340 kg	20,944 lb	10450 kg	23,038 lb	8300 kg	18,298 lb
Operating weight		9920 kg	21,870 lb	10245 kg	22,586 lb	10375 kg	22,872 lb

* Bucket at carry, outside corner of bucket. At the end of tooth or B.O.C.

All dimensions, weights, and performance values based on SAE J732c and J742b standards. Static tipping load and operating weight shown include lubricant, coolant, full fuel tank, ROPS cab, additional counterweight, air conditioning and operator. Machine stability and operating weight affected by counterweight, tire size, and other attachments.

Weight Changes

	Change in Operating Weight		Change in Tipping Load				Width Over Tire	Ground Clearance	Change in Vertical Dimensions			
			Straight		Full Turn							
17.5/25-12PR (L2)	-450 kg	-992 lb	-240 kg	-529 lb	-220 kg	-485 lb	2375 mm	7'10"	425 mm	1'5"	-70 mm	-2.8"
17.5/25-12PR (L3)	-345 kg	-761 lb	-160 kg	-353 lb	-150 kg	-331 lb	2375 mm	7'10"	425 mm	1'5"	-70 mm	-2.8"
20.5/25-12PR (L2)	0 kg	0 lb	0 kg	0 lb	0 kg	0 lb	2470 mm	8'1"	495 mm	1'8"	0 mm	0"
20.5/25-12PR (L3)	+215 kg	+474 lb	+115 kg	+254 lb	+100 kg	+220 lb	2470 mm	8'1"	495 mm	1'8"	0 mm	0"
Install ROPS canopy (instead of cab)	-250 kg	-551 lb	-250 kg	-551 lb	-220 kg	-485 lb	N/A	N/A	N/A	N/A	N/A	N/A
Remove additional counterweight	-300 kg	-661 lb	-590 kg	-1,300 lb	-510 kg	-1,124 lb	N/A	N/A	N/A	N/A	N/A	N/A
Remove air conditioner	-70 kg	-154 lb	-60 kg	-132 lb	-50 kg	-110 lb	N/A	N/A	N/A	N/A	N/A	N/A



STANDARD EQUIPMENT

- Alternator, 60A, 24 volt
- Automatic boom kickout
- Axles, semi floating with torque proportioning
- Back-up alarm
- Back-up light, rear
- Batteries, 110 Ah/2 x 12 V, 950 CCA
- Bucket positioner, automatic
- Cab (ROPS/FOPS level 2) with adjustable wrist rest, cigarette lighter/ash tray, dome light, electrically heated rear window, floor mat, front (intermittent) and rear wiper/washer, rear view mirrors (2 outside, 2 inside), right hand and left hand door access with steps, sun visor
- Counterweight, standard
- Differentials, torque proportioning
- EMMS (Equipment Management Monitoring System)
 - Gauges (speedometer, engine water temperature, fuel level, HST oil temperature)
 - LCD displays (filter/oil replacement time, HST selection, odometer, service meter, trouble shooting)
- Lights (axle oil temperature, battery charge, brake oil pressure, central warning, directional indicator, engine oil pressure, engine pre-heater, HST oil filter clogging, high beam, maintenance, parking brake reminder, parking brake warning, radiator coolant level, steering oil pressure, transmission speed range, turn signals)
- Engine, Komatsu SAA6D102E-2
- Engine shut-off system, electric
- Fan, hydraulic driven, swing out
- Fenders, full front, partial rear
- Fuel water separator
- Horn, electric
- Lift cylinders and bucket cylinder
- Lifting eyes
- Lights
 - Stop and tail
 - Turn signal (2 front, 2 rear)
 - Working (2 front, 2 rear, 2 outside cab)
- Loader linkage with standard lift boom
- Maintenance monitor panel
- Mono-lever loader control with transmission F/R switch
- Parking brake, wet disc
- Radiator mask, hinged
- Seat belt, retractable, 76 mm 3" wide
- Seat, cloth, suspension, reclining with armrests and headrest, and a document holder
- Service brakes, hydraulic, wet multi-disc, inboard
- Speedometer (mph)
- Starting aid, intake manifold preheater
- Starting motor, 4.5 kW/24 V
- Steering wheel, tiltable
- Tires 17.5-25-12PR (L2), tubeless and rims
- Transmission (Hydrostatic with speed range select), automatic
- Transmission control, electric, steering column/loader control lever selectable
- 2-spool valve for boom and bucket controls with PPC
- Vandalism protection kit



OPTIONAL EQUIPMENT

- Air conditioner with heater/defroster/pressurizer
- Air ride seat
- Auxiliary steering
- Bucket, excavating, 1.7 m³ **2.2 yd³**
- Bucket, stockpile, 2.0 m³ **2.6 yd³**
- Bucket, light material, 2.4 m³ **3.1 yd³**
- Bucket teeth, bolt-on
- Counterweight, additional
- Cutting edge, bolt-on, reversible
- ECSS (Electronically Controlled Suspension System)
- Fenders, rear full
- Heater and defroster
- Hydraulic adapter kit (3rd spool), includes valve, lever, and piping
- KOMTRAX™
- JRB bucket, general purpose, for use with coupler, with BOCE 1.9 m³ **2.5 yd³**
- JRB bucket, general purpose, for use with coupler, with BOCE 2.1 m³ **2.75 yd³**
- JRB construction forks, for use with coupler, 1219 mm **48"**
- JRB extendable boom, for use with coupler, 3-section
- JRB hydraulic quick coupler
- Limited-slip differential, front and rear
- Radio, AM/FM stereo with cassette
- Rims only, less tires
 - Fits 17.5-25, 20.5-25, and 550/65 tires
- ROPS canopy
- Tires (bias ply)
 - 17.5-25-12PR (L2)
 - 17.5-25-12PR (L3)
 - 20.5-25-12PR (L2)
 - 20.5-25-12PR (L3)
 Brand preference, Goodyear
- Tires (radial ply)
 - 17.5-R25 XTLA (L2) Michelin
 - 17.5-R25 VKT (L2) Bridgestone
 - 17.5-R25 XHA (L3) Michelin
 - 20.5-R25 VUT (L2) Bridgestone
 - 20.5-R25 XTLA (L2) Michelin
 - 20.5-R25 XHA (L3) Michelin
 - 20.5-R25 VMT (L3) Bridgestone
 - 550/65-R25 XTLA (L2) Michelin
 - 550/65-R25 XLD (L3) Michelin
- Vinyl seat

AESS643-03

©2007 Komatsu America Corp. Printed in USA

K04(5M) C

04/07 (EV-1)

KOMATSU®

