

# KOMATSU®

## 830E-AC

**MAXIMUM GVW**  
385848 kg **850,650 lb**  
**GROSS HORSEPOWER**  
1865 kW **2,500 HP**



Photo may include optional equipment.

ELECTRIC DRIVE TRUCK

# 830E-AC ELECTRIC DRIVE TRUCK

## SPECIFICATIONS



### ENGINE

\*Make and model ..... Komatsu SDA16V160  
 Fuel ..... Diesel  
 Number of cylinders ..... 16  
 Operating cycle ..... 4 cycle  
 \*\*Rated brake power ..... 1865 kW **2,500 HP** @ 1900 rpm  
 \*\*\*Flywheel power ..... 1761 kW **2,360 HP** @ 1900 rpm  
 Weight (wet) ..... 9608 kg **21,182 lb**

\* Tier 2 emissions certified. Tier 1 emissions engine is optional outside of North America.  
 \*\*Rated brake power is the output of the engine as installed in this machine, at governed rpm and with engine manufacturer's approved fuel setting. Accessory losses included are water pump, fuel pump and oil pump  
 \*\*\*Flywheel power is the rated power at the engine flywheel minus the average accessory losses. Accessories include fan and charging alternator. Rating(s) represent gross engine performance in accordance with SAE J1349 conditions.



### ELECTRIC DRIVE

#### AC/DC CURRENT

Alternator ..... G.E. GTA-41  
 Dual impeller in-line blower ..... 255 m<sup>3</sup>/min **9,000 cfm**  
 Control ..... AC torque control system  
 \*Motorized wheels ..... GEB25  
 \*Ratio ..... 31.875:1  
 Speed (maximum) ..... 64 kph **40 mph**

\* Wheel motor application depends upon gross vehicle weight, haul road grade, haul road length, rolling resistance and other parameters. Komatsu and G.E. must analyze each job condition to assure proper application.



### TIRES AND RIMS

Rock service, tubeless, tires (bias ply or radial)  
 Standard tire ..... 40.00R57  
 \*Optional tire ..... 46/90R57  
 Standard five (5) piece rim  
 737 mm x 1488 mm x 152 mm **29" x 57" x 6"** rims.  
 Rated at 827 kPa **120 psi** cold inflation pressure.

Typical tire weight ..... 21081 kg 46,476 lbs

\* Fitment of optional 46/90R57 tire shall increase nominal GVW rating to 392357 kg **865,000 lbs**



### BODY

All-welded steel flat floor body with horizontal bolsters and full canopy. Rear wheel rock ejectors, body up sling and rubber mounts on frame are standard. Pivot exhaust heating optional.

Floor sheet ..... 19 mm **0.75"** 1379 mPa **200,000 psi**  
 tensile strength steel (two-piece)  
 Front sheet ..... 12 mm **0.47"** 1379 mPa **200,000 psi**  
 tensile strength steel  
 Side sheet ..... 8 mm **0.31"** 1379 mPa **200,000 psi**  
 tensile strength steel  
 Canopy sheet ..... 5 mm **0.19"** 690 mPa **100,000 psi**  
 Struck ..... 117 m<sup>3</sup> **153 yd<sup>3</sup>**  
 Standard SAE heaped 2:1 ..... 147 m<sup>3</sup> **193 yd<sup>3</sup>**  
 Standard Komatsu body weight ..... 27669 kg **61,000 lbs**



### CAB

Advanced Operator Environment with integral 4-post ROPS/FOPS structure (meets J1040 Apr88), adjustable air suspension seat w/lumbar support and arm rests, passenger seat, maximum R-value insulation, tilt and telescoping steering wheel, electric windshield wipers w/washer, tinted safety glass, power windows, Komatsu Payload Weighing System, 55,000 Btu/hr heater and defroster, 21,600 Btu/hr air conditioning (HFC - 134A refrigerant).



### FRAME

Advanced technology, full butt-welded box-sectional ladder-type frame with integral ROPS supports, integral front bumper, rear tubular cross members, steel castings at all critical stress transition zones, rugged continuous horsecollar.

Plate material ..... 482.6 mPa **70,000 psi**  
 tensile strength steel  
 Casting material ..... 620.5 mPa **90,000 psi**  
 tensile strength steel  
 Rail width ..... 305 mm **12"**  
 Rail depth (minimum) ..... 864 mm **34"**  
 Top and bottom plate thickness ..... 32 mm **1.25"**  
 Side plate thickness ..... 16 mm **0.62"**  
 Drive axle mounting ..... Pin and spherical bushing  
 Drive axle alignment ..... Swing link between frame and axle



### BRAKING SYSTEM

Service brakes: all-hydraulic actuated

Front ..... Wheel speed disc.  
 Three calipers on a 1213 mm **47.75"** O.D. disc.  
 Rear ..... Dual disc armature speed.  
 Two 635 mm **25"** O.D. discs per side.  
 One caliper per disc.  
 Emergency brakes ..... Automatically applied prior to hydraulic system pressure dropping below level required to meet secondary stopping requirements.  
 Wheel brake locks ..... Switch-activated  
 Parking brakes ..... Spring-applied, hydraulically released, with speed application protection.  
 Electric dynamic retarder (max.) ..... 2983 kW **4000 hp**  
 Continuously rated high-density blown grids w/retard at engine idle and retard in reverse propulsion.



### SUSPENSION

HYDRAIR® II

Variable rate hydro-pneumatic with integral rebound control.  
 Max. front stroke ..... 335 mm **13.2"**  
 Max. rear stroke ..... 279 mm **11.0"**  
 Max. rear axle oscillation ..... ±10.3°



### COOLING SYSTEM

L&M radiator assembly with sight gauge. Deaeration-type top tank. Dual pass cooling.  
 Radiator frontal area ..... 6.24 m<sup>2</sup> **67.2 ft<sup>2</sup>**



### SERVICE CAPACITIES

Cooling system ..... 568 L **150 U.S. gal**  
 \*Crankcase ..... 280 L **74 U.S. gal**  
 Hydraulic system ..... 946 L **250 U.S. gal**  
 Motor gear box ..... 38 L **10 U.S. gal**  
 Fuel ..... 4542 L **1200 U.S. gal**

\* Includes lube oil filters



**DIMENSIONS**

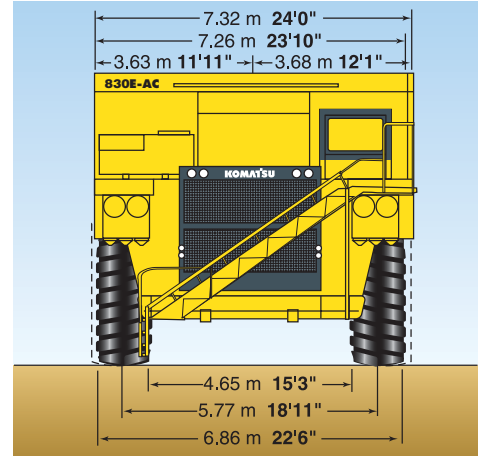
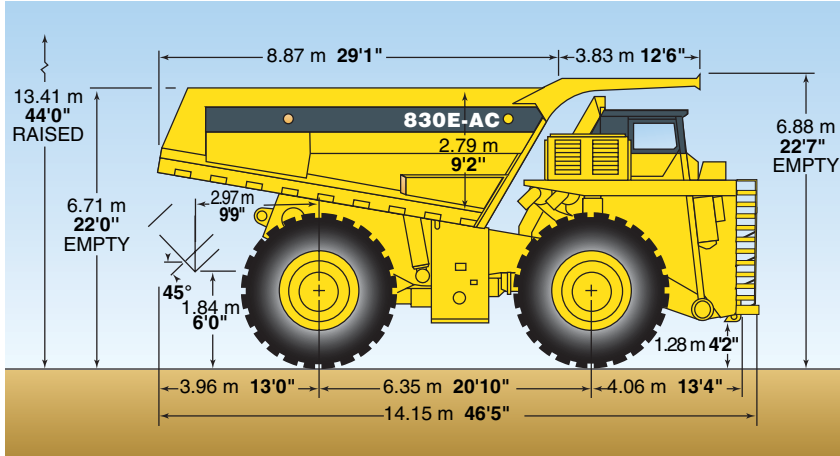

All dimensions are with 147 m<sup>3</sup> 193 yd<sup>3</sup> body.

Bodies	Struck	2:1 Heap	Loading Height*
Standard	117 m <sup>3</sup> 153 yd <sup>3</sup>	147 m <sup>3</sup> 193 yd <sup>3</sup>	6.71 m 22'

\* Exact load may vary due to tire make, type and inflation pressure.

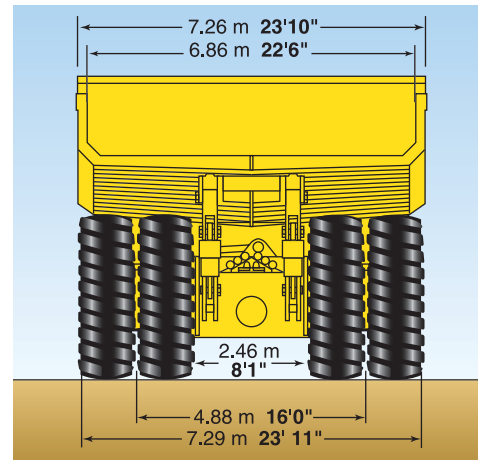

**HYDRAULIC SYSTEM**

- Steering . . . . . Accumulator-assisted twin cylinders provide constant rate steering. Emergency steering automatically supplied by accumulator.
  - Turning circle diameter (SAE) . . . . . 28.4 m 93 ft
  - Reservoir . . . . . 901 L 238 U.S. gal
  - Filtration . . . . . In-line replaceable elements
    - Suction . . . . . Single, full-flow, 100 mesh
    - Hoist and steering . . . . . Dual, in-line, high-pressure.
  - Brake component cabinet. . . . . Above-deck, easily accessible with diagnostic test connections.
  - Hoist . . . . . Two 3-stage dual-acting outboard cylinders, internal cushion valve, over-center damping.
  - Hoist times
    - Power-up loaded . . . . . 25 sec
    - Power-down . . . . . 27 sec
    - Float-down empty . . . . . 24 sec
  - Pumps
    - Hoist . . . . . Tandem gear-type pump with output of 851 lpm 225 gpm@1900 rpm and 17240 kPa 2,500 psi
    - Steering and brake . . . . . Pressure compensating piston pump with output of 246 lpm 65 gpm @ 1900 rpm and 18961 kPa 2,750 psi
  - System relief pressures
    - Hoist . . . . . 17240 kPa 2,500 psi
    - Steering and Brake . . . . . 27580 kPa 4,000 psi
- Quick disconnects standard for powering disabled truck and for system diagnostics.



**ELECTRICAL SYSTEM**

- 4 x 8D 1450 CCA, 12 volt batteries, in series/parallel, deck-mounted with disconnect switch.
- Alternator . . . . . 24 volt, 260 amp
- Lighting . . . . . 24 volt
- Cranking motors . . . . . two/24 volt



**WEIGHT DISTRIBUTION**

Empty Vehicle Weight	kg	lb	%
<small>(Wet, 100% fuel, no options, standard Komatsu body, standard tires)</small>			
Front axle . . . . .	81279	179,190	50
Rear axle . . . . .	82921	182,810	50
Total EVW . . . . .	164200	362,000	
<b>Gross Vehicle Weight (Nominal)</b>			
Front axle . . . . .	127330	280,715	33
Rear axle . . . . .	258519	569,936	67
Total . . . . .	385848	850,650	
Nominal Payload* . . . . .	221648	488,650	
		244 U.S. ton	

\*Nominal payload is as defined within Komatsu America Corporation's payload policy documentation. In general, the nominal payload must be adjusted for the specific vehicle configuration and site application. The figures above are provided for basic product description purposes. Please contact your Komatsu distributor for specific application requirements.



## STANDARD EQUIPMENT

- Air cleaners, Donaldson SRG
- Alternator (24 volt/260A)
- Auto lubrication system –90 lbs.
- Batteries (4 x 8D, 1450 CCA 12 volt)
- Battery charging receptacle, 24 V
- Body down indicator/body up buzzer
- Body over center device
- Brakes: Front: Wheel speed disc; Rear: dual disc armature speed
- Electric start
- Filters, high pressure hydraulic
- Gate valves on hydraulic tank
- Komatsu IGBT control cabinet
- Komatsu Payload Weighing System-PLM III
- Mirrors, LH flat and RH rectangular convex
- Mud flaps
- Muffled exhaust, deck-mounted
- On-board load box
- Quick disconnects (steering and hoist)
- Radiator sight gauge
- Removable power module unit (radiator, engine, alternator, blower)
- Retard grids, continuous rated, 14 element
- Retard speed control
- Reverse retarding
- Rock ejectors
- Thermostatic Fan Clutch
- Vari-volt alternator control
- Fast-Fill Fuel System (in-tank)
- Service Center (radiator, engine, hydraulics)

### SAFETY:

- All-hydraulic service brakes with emergency auto apply
- Battery disconnect switch
- Body up cable
- Brake lock and drive system interlock
- Circuit breakers, 24 volt
- Diagonal staircase across grill
- Dynamic retarding with continuous rated grids
- Engine shutdown at ground level
- Hoist interlock

- Horns (electric, center of steering wheel)
- Integral roll-over protection (ROPS)
- Maintenance & power lock-out
- Parking brake with warning light and speed application protection
- Power steering w/auto emergency steering
- Protective deck rails
- Pump drive guard
- Radiator fan guard
- Seat belts 76 mm 3" retractable
- Skid-resistant coating on walkways

### STANDARD HIGH VISIBILITY DELUXE CAB:

#### Instrumentation

- Alarm System warning lights (red)
  - Accumulator pre-charge
  - Coolant low level w/alarm
  - Coolant high temperature w/alarm
  - Electric drive system cooling blower w/alarm
  - Electric system fault w/alarm
  - Engine coolant temperature gauge
  - Hydraulic oil level w/alarm
  - Hydraulic oil temperature w/alarm
  - Low engine oil pressure w/alarm
  - Low brake pressure w/alarm
  - Motorized wheel temperature stop engine w/alarm
  - Steering pressure w/alarm
- Air cleaner vacuum indicators
- Air conditioner HFC 134a
- AM/FM cassette radio, XM capable
- Blower pressure indicator light
- Digital tachometer and speedometer
- Dome light
- Engine hourmeter
- Engine shutdown
- Floor mat
- Fuel gauge in cab and on tank
- Fuel low level warning
- Gauges (backlighted)
- Headlight switch
- Heater and defroster (heavy-duty)
- Heater switch

- High beam selector and indicator
- Indicator lights (amber):
  - 5-minute idler timer
  - Auto lube alarm
  - Check engine w/alarm
  - Circuit breaker tripped
  - Dynamic retarding
  - Dump body up
  - Hydraulic oil filter
  - Low fuel level
  - Manual back-up lights
  - Park brakes applied
  - Retard speed control
  - Service brakes
  - Starter circuit
- Insulation (Max R-Value)
- Oil pressure gauge (engine)
- Operator seat, adjustable w/air suspension, lumbar support and arm rests
- Panel lighting (adjustable)
- Passenger seat
- Power windows
- Pressurized cab air system
- RS232 port–PLM III
- Starter key switch
- Steering system warning light and buzzer
- Sunvisor (adjustable)
- Tilt and telescoping steering wheel
- VHMS with ORBCOMM
- Windshield (tinted safety plate)
- Windshield wipers and washer (electric)

### LIGHTING:

- Back-up lights (2)
- Brake and retard lights on top of cab
- Clearance lights
- Control cabinet service light
- Dynamic retarding, rear (2)
- Headlights—(4) halogen
- Ladder lights
- Manual back-up light, switch and indicator
- Service light in rear axle
- Stop and tail lights (2)
- Turn signals
- Under-hood service lights



## OPTIONAL EQUIPMENT

(Optional equipment may change operating weight).

- Additional high-mounted headlights
- Air cleaner dust evacuators
- Arctic protection package (suspensions, antifreeze/lube below -40° C)
- Back-up lights, deck-mounted
- Body liners\*
- Eliminator, Centinel, Reserve
- Engine: SDA16V160 Tier 1 emissions package is optional outside North America
- Fire extinguisher 9 kg **20 lb**
- Fog lights
- Hot starts (engine oil, coolant, hydraulic tank)
- Hubodometer
- Modular Mining Systems (MMS) ready
- Mufflers between frame rails
- Pivot exhaust (heated body)
- Pressure fueling remote LH
- Radiator shutters
- Special language decals
- Tires 46/90R57

\*Available factory installed or non-installed. All other options and accessories listed are available factory installed only.

AESS672-01

©2006 Komatsu Printed in USA

DK03(1.5M) C

03/06 (EV-1 )

# KOMATSU®