

KOMATSU®

PC300LC-7

With Tier 3 Engine

FLYWHEEL HORSEPOWER
184 kW **246 HP** @ 1950 rpm

OPERATING WEIGHT
32860–35070 kg
72,432–77,298 lb

BUCKET CAPACITY
0.68–1.96 m³ **0.89–2.56 yd³**

PC
300
LC

HYDRAULIC EXCAVATOR



Photo may include optional equipment.

WALK-AROUND

Productivity Features

- ***High Production and Low Fuel Consumption***

High power, working performance and fuel efficiency improve production and fuel costs.

- ***Large Drawbar Pull***

provides superb steering and slope climbing performance.

- ***Higher Lifting Capacity***

Lifting mode is provided for superb lifting operation.

- ***Large Digging Force***

Pressing the Power Max function button temporarily increases digging force by 8%.

- ***Multi-Function Color Monitor***

- Working mode selection
- Self-diagnostic with EMMS
- Attachment hydraulic oil flow adjustment in cab

- ***Automatic Three Speed Travel***

- ***General Features***

- OPG top guard level 2 capable, with optional bolt on top guard
- Engine neutral start with lock lever
- High-visibility cab with two (2) front, one (1) side and one (1) rear mirrors
- Slip-resistant plates for improved foot grip



Easy Maintenance

- Extended replacement interval of engine oil, engine oil filter and hydraulic filter
- Equipped with 10 micron fuel pre-filter as standard (with water separator)
- Side-by-side cooling concept enables individual cooling modules to be serviced
- Equipped with the EMMS monitoring system
- Easy access to engine oil filter and fuel drain valve
- Large fuel tank capacity
- Equipped with KOMTRAX (standard)

KOMTRAX™

KOMTRAX equipped machines can send location, SMR and operation maps to a secure website utilizing wireless technology. Additionally, most Step II capable machines can relay error codes, cautions, maintenance items, fuel levels, and much more.

Ecology and Economy Features

- Low emission engine
- A powerful turbocharged and air-to-air aftercooled Komatsu SAA6D114E-3 engine provides 184 kW **246 HP**. This engine is EPA Tier 3 and EU stage 3A emission certified, without sacrificing power or machine productivity.
- Economy mode reduces fuel consumption
- Low operation noise

Large Comfortable Cab

- Low noise design
- Low vibration with cab damper mounting
- Highly pressurized cab with automatic air conditioner

Excellent Reliability and Durability

- High rigidity work equipment
- Sturdy frame structure
- Reliable Komatsu manufactured major components
- Highly reliable electronic devices

FLYWHEEL HORSEPOWER

Net: 184 kW 246 HP @ 1950 rpm

OPERATING WEIGHT

32860 – 35070 kg

72,432 – 77,298 lb

BUCKET CAPACITY0.68 – 1.96 m³0.89 – 2.56 yd³

Photo may include optional equipment.

PRODUCTIVITY FEATURES



Komatsu's new "ecot3" engines are designed to deliver optimum performance under the toughest of conditions, while meeting the latest environmental regulations. This engine is Tier 3 EPA, EU Stage 3A and Japan emissions certified; "ecot3" - ecology and economy combined with Komatsu technology to create a high performance engine without sacrificing power or productivity.

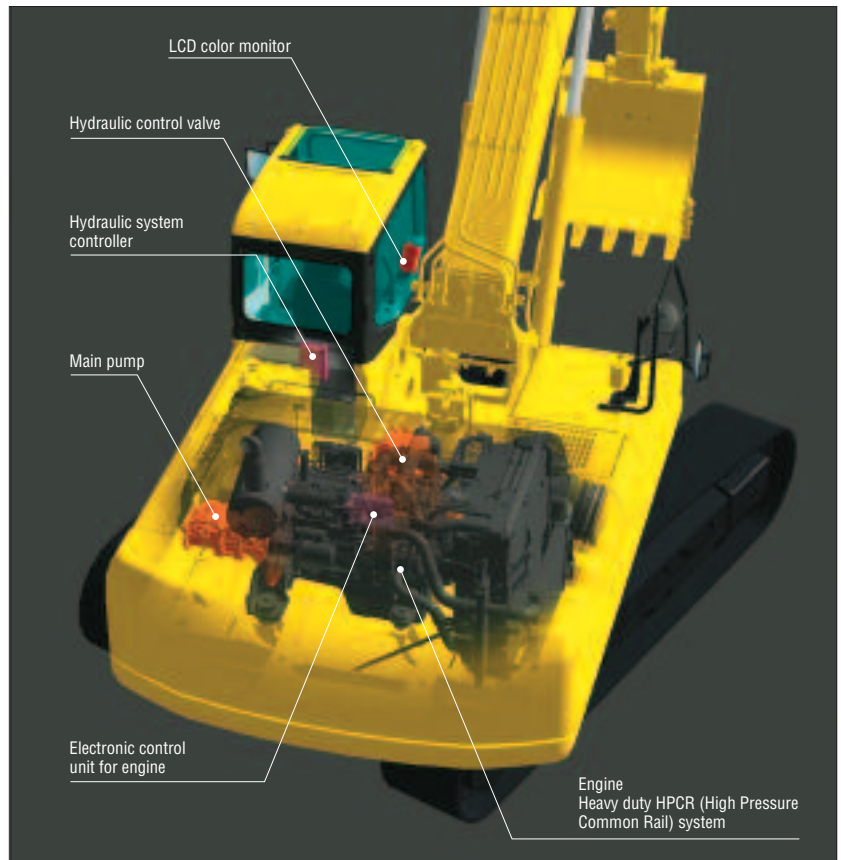

Environment-Friendly Clean Engine

The PC300LC-7 gets its exceptional power and work capacity from a Komatsu SAA6D114E-3 engine. Output is 184 kW **246 HP**, providing increased hydraulic power and improved fuel efficiency.

Komatsu SAA6D114E-3 is EPA Tier 3 and EU stage 3A emissions certified with NOx emission reduced by 33%. The SAA6D114E-3 engine adopts the electronically controlled Heavy Duty HPCR* fuel injection system.

*HPCR: High Pressure Common Rail

Hydraulics

Unique two-pump system ensures smooth compound movement of the work equipment. HydrauMind controls both pumps for efficient engine power use. This system also reduces hydraulic loss during operation.

Low Operation Noise

The dynamic noise is lowered by 1 dB, realizing a lower operational noise.



Large Maximum Drawbar Pull

Large maximum drawbar pull provides superb steering and slope climbing performance.

Maximum drawbar pull:
264 kN 26900 kgf
59,300 lb



Large Digging Force

With the one-touch Power Max function, digging force is further increased (8.5 seconds of operation).

Maximum arm crowd force (ISO):

160 kN (16.3t) ➔ **171 kN (17.4t)** 8% UP
with Power Max.

Maximum bucket digging force (ISO):

212 kN (21.6t) ➔ **227 kN (23.1t)** 8% UP
with Power Max.

*Measured with Power Max function, 3185 mm 10'5" arm and ISO rating.

Smooth Loading Operation

Two return hoses improve hydraulic performance. In the arm out function, a portion of the oil is returned to the tank smoothly.



Two Boom Settings

Smooth mode provides easy operation for fine work or scraping down operation. When maximum digging force is needed, switch to Power mode for more effective excavating.

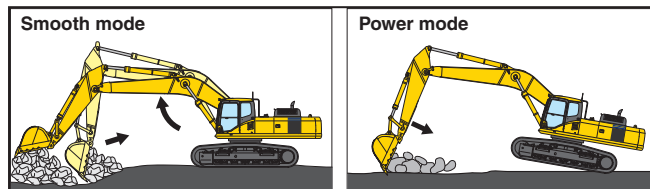

Smooth mode
Boom floats upward, reducing lifting of machine front. This facilitates fine work and scraping down operations.

Power mode
Boom force is at maximum for normal production digging.

Automatic Three-Travel Speed

Travel speed is automatically shifted from high to low speed according to the pressure demand on travel circuit.

Working Mode Selection

The PC300LC-7 excavator is equipped with four working modes (P, E, L, and B mode). Each mode is designed to match engine speed, pump flow, and system pressure with the current application. This provides the flexibility to match equipment performance to the job at hand.

Working Mode	Application	Advantage
P	Power mode	<ul style="list-style-type: none"> Maximum production/power Fast cycle times
E	Economy mode	<ul style="list-style-type: none"> Excellent fuel economy
L	Lifting mode	<ul style="list-style-type: none"> Hydraulic pressure is increased by 7%
B	Breaker mode	<ul style="list-style-type: none"> Optimum engine rpm, hydraulic flow for breaker operation



Power/Economy Mode

The PC300LC-7 offers two operator selectable working modes. Power mode for severe or high production applications. Economy mode allows significant fuel savings at slightly reduced production levels.

Lifting Mode

When the lifting mode is selected, lifting capacity is increased 7% by raising hydraulic pressure.

WORKING ENVIRONMENT

PC300LC-7 cab interior is spacious and provides a comfortable working environment...

Large Comfortable Cab

Multi-Position Controls

The multi-position, PPC (pressure proportional control) levers allow the operator to work in comfort while maintaining precise control. A double-slide mechanism allows the seat and controllers to move together or independently, allowing the operator to position for maximum productivity and comfort.

Low Cab Noise

Cab is highly rigid and has excellent sound absorption ability. Thorough improvement of noise source reduction and use of low noise engine, hydraulic equipment, and air conditioner allows this machine to generate a low level of noise.

Low Vibration with Cab Damper Mounting

PC300LC-7 uses a multi-layer viscous mount system that incorporates longer stroke and the addition of a spring. The new cab damper mounting combined with high rigidity deck reduces vibration at the operator's seat.

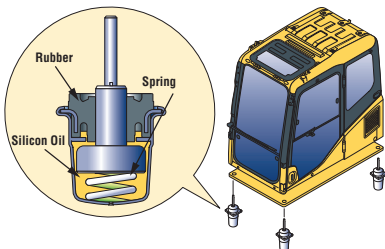

Photo may include optional equipment.



Seat Sliding Amount: 340 mm 13.4"

Comfortable Cab

Wide spacious cab includes seat with reclining backrest. The seat height and longitudinal inclination are easily adjusted using a pull-up lever. Seat can be fully reclined with headrest attached.



Pressurized Cab

With automatic air conditioner, air filters, and a higher internal air pressure (+6.0 mm Aq + 0.2" Aq), external dust is prevented from entering the cab.

Automatic Air Conditioner

A 6900 kcal **27,400 Btu** air conditioner is utilized. The bi-level control function keeps the operator's head and feet cool and warm respectively. This improved air flow function keeps the inside of the cab comfortable throughout the year. Defroster function keeps cab glass clear.

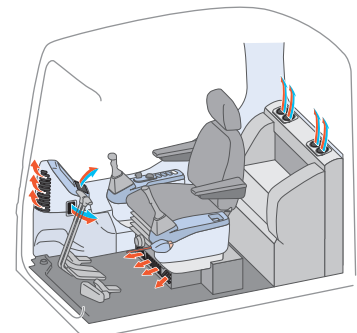

GENERAL FEATURES

Cab

OPG top guard level 2 capable, with optional bolt-on top guard.

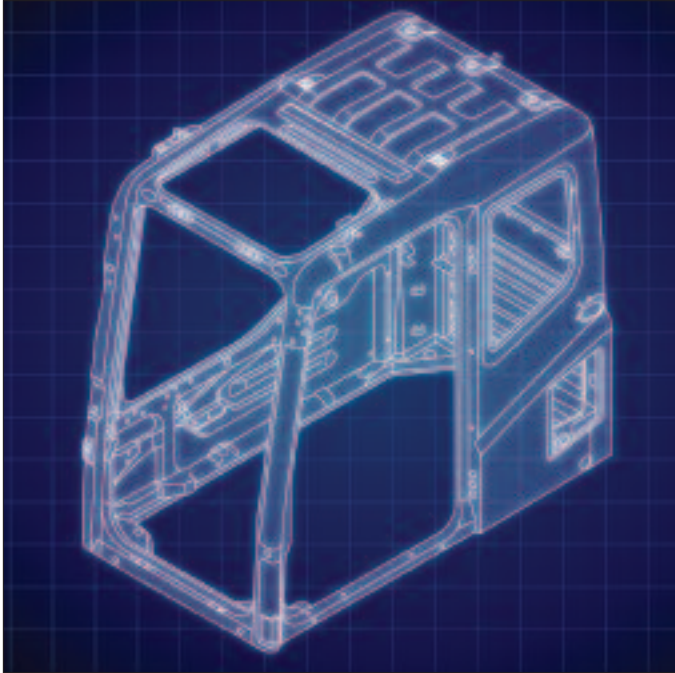

OPG Level 2 Top Guard (optional)

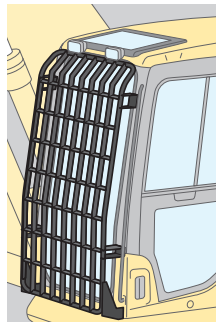

Front Full Guard Level 2 (optional)

Wide Visibility

Highly rigid cab allows for increased glass area and provides superior all around visibility to work area.



Slip-Resistant Plates

Highly durable slip-resistant plates maintain superior foot traction performance for the long term.

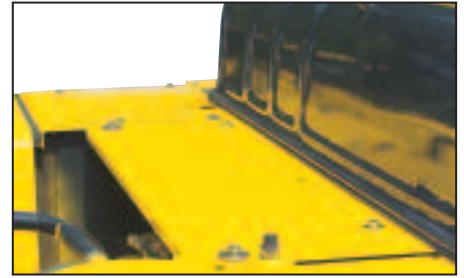

Lock Lever

Makes all hydraulic cab controls inoperable. Neutral start function allows machine to be started only in lock position.



Large Side-View, Rear, and Sidewise Mirrors

Enlarged left-side mirror and the addition of rear and side mirrors allow the PC300LC-7 to meet new one-meter boundary ISO visibility requirements.



Pump/Engine Room Partition

Pump/engine room partition prevents oil from spraying on the engine if a hydraulic hose should burst.

Thermal and Fan Guards

Thermal and fan guards are placed around high-temperature parts of the engine and fan drive.



Large Serrated Steps



Large Hand Rail

MAINTENANCE FEATURES

Self-Diagnostic Monitor

The PC300LC-7 features the most advanced diagnostics system in the industry. This Komatsu exclusive system identifies maintenance items, reduces diagnostic times, indicates oil and filter replacement hours and displays error codes.

Continuous Machine Monitoring System

When starting switch is turned ON, check-before-starting items and caution items appear on the liquid crystal panel. If abnormalities are found, a warning lamp blinks and a warning buzzer sounds. Continuous machine condition checks help prevent the development of serious problems and allows the operator to concentrate on the work at hand.

Easy Maintenance

Komatsu designed the PC300LC-7 to have easy service access. We know by doing this, routine maintenance and servicing are more likely to be performed, which can mean a reduction in costly downtime later on. Here are some of the many service features found on the PC300LC-7.

Easy Radiator Cleaning

Since radiator and oil cooler are side-by-side modules, it is easy to clean, remove, and install them.

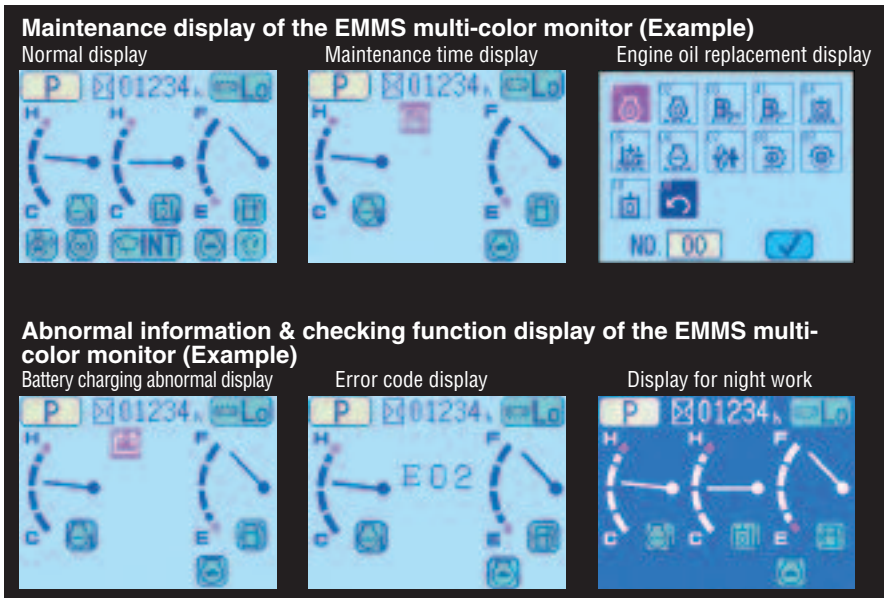
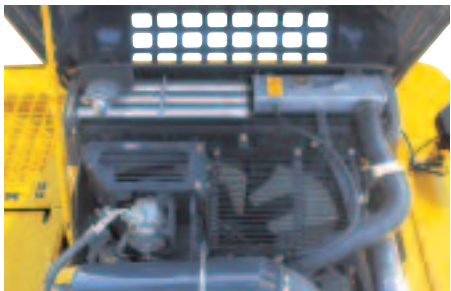

Abnormalities on Electronic System Display with Code

When an error occurs during operation, a user code is displayed. When an important user code is displayed, a caution lamp blinks and a warning buzzer sounds to prevent the development of serious problems.

Easy Access to Engine Oil filter and Fuel Drain Valve

Engine oil level check, oil fill port, and fuel filter are one side mounted to improve accessibility. Engine oil filter and fuel drain valve are remotely mounted to improve accessibility.



Maintenance Function

When machine exceeds oil or filter replacement time, the maintenance monitor lights to inform operator.

Trouble Data Memory Function

Monitor stores abnormalities for effective troubleshooting.



Engine Oil Filter



Fuel Drain Valve

Equipped with Fuel Pre-Filter (with Water Separator)

Removes water and contaminants in the fuel to prevent fuel problems.



Equipped with the Eco-Drain Valve as Standard

Provides for easier and cleaner engine oil changes.

Maintenance Costs Reduced

Extended Replacement Intervals for Hydraulic Oil and Filter/Engine Oil and Filter

High performance filters are used in hydraulic circuit and engine. Longer hydraulic oil filter, engine oil, and engine oil filter element replacement intervals significantly reduce maintenance costs.

Engine oil & Engine oil filter	every 500 hours
Hydraulic oil	every 5000 hours
Hydraulic oil filter	every 1000 hours



Extended Work Equipment Greasing Interval

High quality BMRC bushings and resin shims are installed in the work equipment, excluding bucket, extending greasing interval to 500 hours.

High-Capacity Air Cleaner

High capacity air cleaner is comparable to that of larger machines. The large air cleaner extends filter element life and extends service intervals.



High-Pressure In-Line Filter

The PC300LC-7 has high pressure in-line filters installed at the pump discharge ports. This protects the hydraulic system from contamination due to the unlikely event of a pump failure.

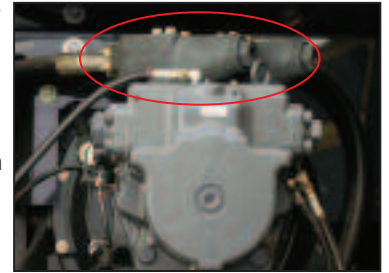

RELIABILITY AND FEATURES

High Rigidity Work Equipment

Thanks to large cross-sectional structures, thick high tensile strength steel, and partition walls, the boom and arm exhibit excellent durability and are highly resistant to bending and torsional stress.

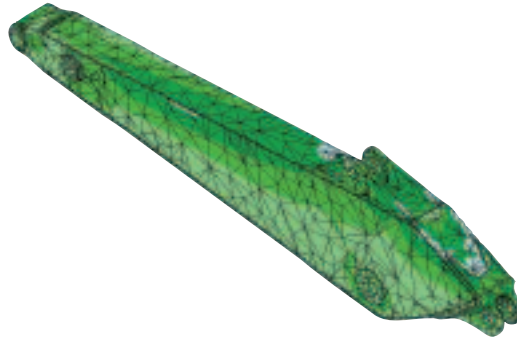

Sturdy Frame Structure

The revolving frame, center frame, and undercarriage are designed using the most advanced three-dimensional CAD and FEM analysis technology.



Reliable Components

All of the major machine components, such as engine, hydraulic pumps, hydraulic motors, and control valves are exclusively designed and manufactured by Komatsu.

Highly Reliable Electronic Devices

Exclusively designed electronic devices have passed severe testing.

- Controllers
- Sensors
- Connectors
- Heat resistant wiring

Metal guard rings protect all the hydraulic cylinders and improve reliability.

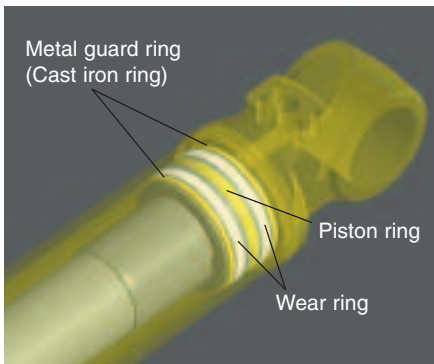

DT-Type Connectors

DT-type connectors seal tight and have higher reliability.

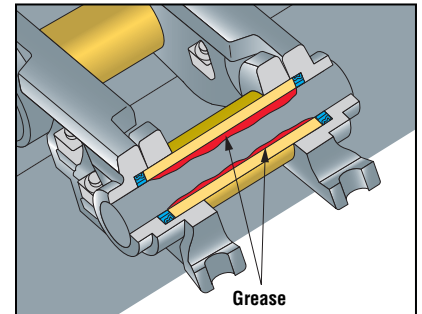
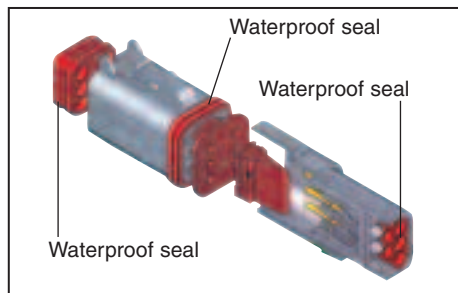

Grease Sealed Track

PC300LC-7 uses grease sealed tracks for extended undercarriage life.

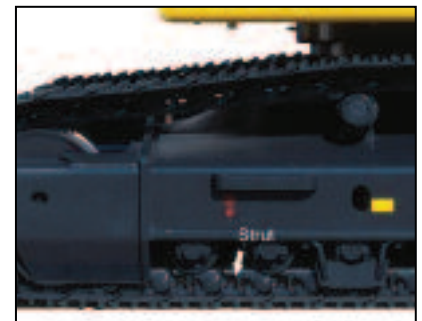

Track Link with Strut

PC300LC-7 uses track links with strut providing superb durability.

O-Ring Face Seal

Hydraulic hoses are equipped with O-ring seals versus conventional taper seal, to provide extended leak-free life.



LCD Multi-Function Color Monitor

LCD Color Graphics Screen

LCD multi-color monitor displays color graphics as well as character display. Color variation in the display screen contributes to improved visibility



Display screen during nighttime hours (working light "ON")

Hydraulic Pump Oil Flow Adjustment System

When installing attachments, it is possible to adjust hydraulic pump flow to match attachment requirements. Selection is possible through the LCD (Liquid Crystal Display).

Breaker mode selected, one-way flow.

Flow rate can be adjusted according to the breaker requirement.



Flow rate fine adjustment display screen

P or E mode selected, two-way flow (thumb, shear)

Flow rate can be adjusted according to the attachment requirements. When work equipment and the attachment are operated simultaneously, hydraulic flow is distributed to maintain smooth compound operation.



Flow rate fine adjustment display screen



Indicators

- 1 Working mode
- 2 Service meter
- 3 Travel speed
- 4 Engine water temperature gauge
- 5 Hydraulic oil temperature gauge
- 6 Fuel gauge
- 7 Swing parking brake
- 8 Preheater
- 9 Wiper
- 10 Auto-decelerator
- 11 Power Max.

Switches

- 1 Power mode
- 2 Economy mode
- 3 Lifting mode
- 4 Breaker mode
- 5 Buzzer cancel
- 6 Selector switch
- 7 Auto-decelerator
- 8 Travel speed selection
- 9 Screen adjustment switch
- 10 Maintenance mode
- 11 Wiper
- 12 Windshield washer
- 13 Input control switches

PC300LC-7 HYDRAULIC EXCAVATOR

SPECIFICATIONS



ENGINE

Model Komatsu SAA6D114E-3
 Type Water-cooled, 4-cycle, direct injection
 Aspiration Turbocharged and aftercooled
 Number of cylinders 6
 Bore 114 mm **4.49"**
 Stroke 135 mm **5.31"**
 Piston displacement 8.27 ltr **505 in³**
 Horsepower
 SAE J1995 Gross 194 kW **260 HP**
 ISO 9249/SAE J1349 Net 184 kW **246 HP**
 Rated rpm 1950 rpm
 Fan drive type Mechanical
 Governor All-speed, electronic
 EPA Tier 3 and EU Stage 3A emission certified.



HYDRAULIC SYSTEM

Type HydrauMind (Hydraulic Mechanical Intelligence New Design) system, closed-center system with load sensing valves and pressure compensated valves
 Number of selectable working modes 4
 Main pump:
 Type Variable displacement piston type
 Pumps for Boom, arm, bucket, swing, and travel circuits
 Maximum flow 535 ltr/min **141 U.S. gal/min**
 Supply for control circuit Self-reducing valve
 Hydraulic motors:
 Travel 2 x axial piston motors with parking brake
 Swing 1 x axial piston motor with swing holding brake
 Relief valve setting:
 Implement circuits 37.3 MPa 380 kg/cm² **5,400 psi**
 Travel circuit 37.3 MPa 380 kg/cm² **5,400 psi**
 Swing circuit 27.9 MPa 285 kg/cm² **4,050 psi**
 Pilot circuit 3.2 MPa 33 kg/cm² **470 psi**
 Hydraulic cylinders:
 Number of cylinders—bore x stroke x rod diameter
 Boom 2 – 140 mm x 1480 mm x 100 mm **5.5" x 58.3" x 3.9"**
 Arm 1 – 160 mm x 1825 mm x 110 mm **6.3" x 71.9" x 4.3"**
 Bucket for 3.2 m **10'5"** and 4.0 m **13'2"** Arms
 1-140 mm x 1285 mm x 100 mm **5.5" x 50.6" x 3.9"**
 for 2.54 m **8'4"** Arm
 1-150 mm x 1285 mm x 110 mm **5.9" x 50.6" x 4.3"**



DRIVES AND BRAKES

Steering control Two levers with pedals
 Drive method Hydrostatic
 Maximum drawbar pull 264 kN 26900 kg **59,300 lb**
 Gradeability 70%, 35°
 Maximum travel speed: High 5.5 km/h **3.4 mph**
 (Auto-shift) Mid 4.5 km/h **2.8 mph**
 Low 3.2 km/h **2.0 mph**
 Service brake Hydraulic lock
 Parking brake Mechanical disc brake



SWING SYSTEM

Drive method Hydrostatic
 Swing reduction Planetary gear
 Swing circle lubrication Grease bathed
 Service brake Hydraulic lock
 Holding brake/Swing lock Mechanical disc brake
 Swing speed 9.5 rpm
 Swing torque 11386 kg·m **82,313 ft. lbs.**



UNDERCARRIAGE

Center frame X-frame
 Track frame Box-section
 Track type Sealed
 Track adjuster Hydraulic
 No. of shoes 48 each side
 No. of carrier rollers 2 each side
 No. of track rollers 8 each side



COOLANT AND LUBRICANT CAPACITY (REFILLING)

Fuel tank 605 ltr **160 U.S. gal**
 Coolant 30.3 ltr **8.0 U.S. gal**
 Engine 35.0 ltr **9.2 U.S. gal**
 Final drive, each side 8.5 ltr **2.2 U.S. gal**
 Swing drive 13.4 ltr **3.5 U.S. gal**
 Hydraulic tank 188 ltr **49.7 U.S. gal**



OPERATING WEIGHT (APPROXIMATE)

Operating weight, including 6500 mm **21'3"** one-piece boom, 3185 mm **10'5"** arm, SAE heaped 1.96 m³ **2.56 yd³** bucket, rated capacity of lubricants, coolant, full fuel tank, operator, and standard equipment.

Triple-Grouser Shoes	Operating Weight	Ground Pressure
*700 mm 28"	32860 kg 72,432 lb	0.54 kg/cm ² 7.70 psi
800 mm 31.5"	34190 kg 75,376 lb	0.49 kg/cm ² 6.97 psi
850 mm 33.5"	34380 kg 75,795 lb	0.47 kg/cm ² 6.68 psi

* with 1.21 yd³ **30"** bucket and "4PL01" standard counterweight



WORKING FORCES

	Arm	2540 mm 8'4"	3185 mm 10'5"	4020 mm 13'2"
SAE rating	Bucket digging force at power max.	23300 kgf 51,370 lb	20400 kgf 44,970 lb	20400 kgf 44,970 lb
	Arm crowd force at power max.	19700 kgf 43,430 lb	16800 kgf 37,040 lb	14200 kgf 31,310 lb
ISO rating	Bucket digging force at power max.	26400 kgf 58,200 lb	23100 kgf 50,930 lb	23100 kgf 50,930 lb
	Arm crowd force at power max.	20500 kgf 45,190 lb	17400 kgf 38,360 lb	14700 kgf 32,410 lb



DIMENSIONS

	Arm Length	2540 mm 8'4"	3185 mm 10'5"	4020 mm 13'2"
A	Overall length	11180 mm 36'8"	11140 mm 36'7"	11170 mm 36'8"
B	Length on ground (transport):	6760 mm 22'2"	5930 mm 19'5"	5475 mm 18'0"
C	Overall height (to top of boom)	3410 mm 11'2"	3280 mm 10'9"	3760 mm 12'4"
D	Overall width	3390 mm 11'2"		
E	Overall height (to top of cab)	3130 mm 10'3"		
F	Ground clearance, counterweight	1185 mm 3'11"		
G	Ground clearance (minimum)	500 mm 1'8"		
H	Tail swing radius	3450 mm 11'4"		
I	Track length on ground	4030 mm 13'3"		
J	Track length	4955 mm 16'3"		
K	Track gauge	2590 mm 8'6"		
L	Width of crawler	3390 mm 11'2"		
M	Shoe width	800 mm 31.5"		
N	Grouser height	36 mm 1.4"		
O	Machine cab height	2580 mm 8'6"		
P	Machine cab width	2995 mm 9'10"		
Q	Distance, swing center to rear end	3405 mm 11'2"		

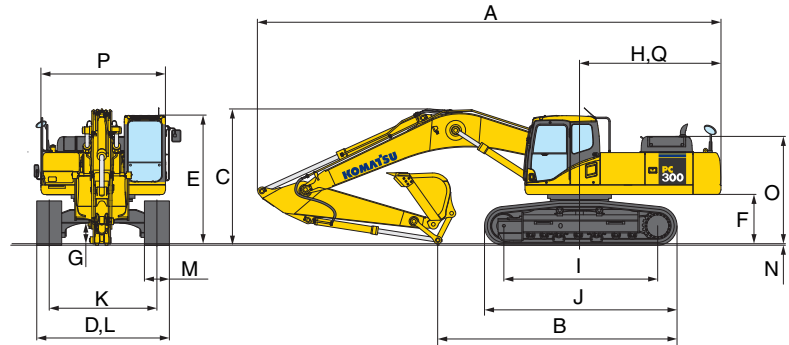

BACKHOE BUCKET, ARM, AND BOOM COMBINATION

Bucket Type	Bucket			Arms		
	Capacity	OLW	Weight	2540 mm 8'4"	3185 mm 10'5"	4020 mm 13'2"
Komatsu GSK	0.68 m ³ 0.89 yd ³	610 mm 24"	878 kg 1,935 lb	V	V	V
	0.93 m ³ 1.21 yd ³	762 mm 30"	1012 kg 2,230 lb	V	V	V
	1.18 m ³ 1.54 yd ³	914 mm 36"	1102 kg 2,430 lb	V	V	V
	1.44 m ³ 1.88 yd ³	1067 mm 42"	1221 kg 2,691 lb	V	V	W
	1.70 m ³ 2.22 yd ³	1219 mm 48"	1308 kg 2,883 lb	W	W	X
	1.96 m ³ 2.56 yd ³	1372 mm 54"	1427 kg 3,146 lb	X	X	Y
Komatsu HP	0.68 m ³ 0.89 yd ³	610 mm 24"	1022 kg 2,254 lb	V	V	V
	0.93 m ³ 1.21 yd ³	762 mm 30"	1178 kg 2,598 lb	V	V	V
	1.18 m ³ 1.54 yd ³	914 mm 36"	1358 kg 2,993 lb	V	V	V
	1.44 m ³ 1.88 yd ³	1067 mm 42"	1439 kg 3,173 lb	V	V	X
	1.70 m ³ 2.22 yd ³	1219 mm 48"	1555 kg 3,429 lb	W	X	Y
	1.96 m ³ 2.56 yd ³	1372 mm 54"	1701 kg 3,750 lb	X	Y	Z
Komatsu HPS	0.68 m ³ 0.89 yd ³	610 mm 24"	1112 kg 2,451 lb	V	V	V
	0.93 m ³ 1.21 yd ³	762 mm 30"	1294 kg 2,853 lb	V	V	V
	1.18 m ³ 1.54 yd ³	914 mm 36"	1437 kg 3,167 lb	V	V	V
	1.44 m ³ 1.88 yd ³	1067 mm 42"	1607 kg 3,543 lb	V	W	X
	1.70 m ³ 2.22 yd ³	1219 mm 48"	1750 kg 3,857 lb	W	X	Y
	1.96 m ³ 2.56 yd ³	1372 mm 54"	1921 kg 4,236 lb	X	Y	Z
Komatsu HPX	0.68 m ³ 0.89 yd ³	610 mm 24"	1239 kg 2,731 lb	V	V	V
	0.93 m ³ 1.21 yd ³	762 mm 30"	1421 kg 3,133 lb	V	V	V
	1.18 m ³ 1.54 yd ³	914 mm 36"	1564 kg 3,447 lb	V	V	W
	1.44 m ³ 1.88 yd ³	1067 mm 42"	1734 kg 3,823 lb	V	W	X
	1.70 m ³ 2.22 yd ³	1219 mm 48"	1877 kg 4,137 lb	X	X	Y
	1.96 m ³ 2.56 yd ³	1372 mm 54"	2048 kg 4,516 lb	Y	Y	Z

V – Used with weights up to 3,500 lb/yd³, W – Used with weights up to 3,000 lb/yd³
 X – Used with weights up to 2,500 lb/yd³, Y – Used with weights up to 2,000 lb/yd³, Z – Not useable

WORKING RANGES



WORKING RANGE

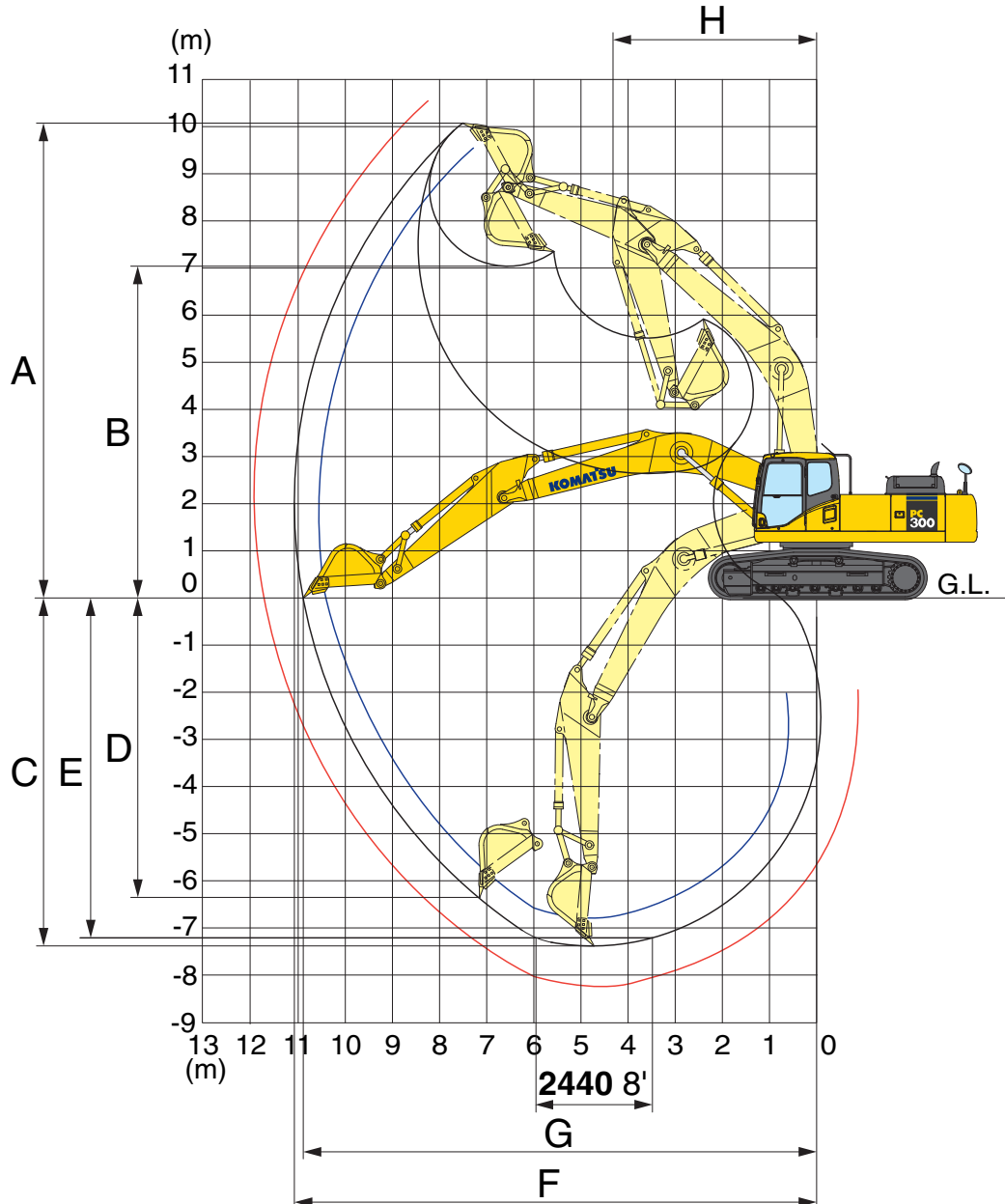

	Arm	2540 mm 8'4"	3185 mm 10'5"	4020 mm 13'2"
A	Max. digging height	9965 mm 32'8"	10210 mm 33'6"	10550 mm 34'7"
B	Max. dumping height	6895 mm 22'7"	7110 mm 23'4"	7490 mm 24'7"
C	Max. digging depth	6705 mm 22'0"	7380 mm 24'3"	8180 mm 26'10"
D	Max. vertical wall digging depth	5880 mm 19'4"	6480 mm 21'3"	7280 mm 23'11"
E	Max. digging depth of cut for 8' level	6520 mm 21'5"	7180 mm 23'7"	8045 mm 26'5"
F	Max. digging reach	10550 mm 34'7"	11100 mm 36'5"	11900 mm 39'1"
G	Max. digging reach at ground level	10355 mm 34'0"	10920 mm 35'10"	11730 mm 38'6"
H	Min. swing radius	4400 mm 14'5"	4310 mm 14'2"	4320 mm 14'2"

LIFTING CAPACITIES



LIFTING CAPACITY

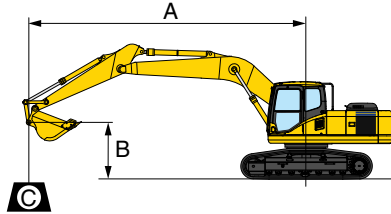

- A: Reach from swing center
- B: Bucket hook height
- C: Lifting capacity
- Cf: Rating over front
- Cs: Rating over side
- ⊗: Rating at maximum reach

Conditions:

- Arm: 2540 mm 8'4"
- Boom length 6500 mm 21'3"
- Bucket 1.4 m³ 1.83 yd³ (SAE heaped)
- Bucket weight: 1021 kg 2,252 lb.

PC300LC-7		Shoe 800 mm 31'5"										Unit: kg/lb	
B	A MAX	3.0 m 10'		4.6 m 15'		6.1 m 20'		7.6 m 25'		9.1 m 30'		⊗ MAX	
		Cf	Cs	Cf	Cs	Cf	Cs	Cf	Cs	Cf	Cs	Cf	Cs
7.6 m 25'	7.1 m 23'											*7600 *16,850	7400 16,300
6.1 m 20'	8.1 m 26'							*7950 *17,550	6400 14,150			*7450 *16,450	5750 12,750
4.6 m 15'	8.7 m 28'			*12550 *27,700	*12550 *27,700	*9800 *21,600	8950 19,750	*8350 *18,450	6200 13,750			*7650 *16,850	4950 10,950
3.0 m 10'	9.0 m 29'			*15200 *33,550	12850 28,400	*11000 *24,300	8400 18,550	*8900 *19,700	5950 13,150			7250 16,050	4500 10,000
1.5 m 5'	9.0 m 30'			*16800 *37,050	12000 26,450	*11950 *26,400	7950 17,500	9250 20,350	5700 12,600			7100 15,650	4350 9,650
0 m 0'	8.8 m 29'			*16800 *37,050	11650 25,750	*12300 *27,200	7650 16,900	9050 19,950	5550 12,200			7250 16,050	4450 9,850
-1.5 m -5'	8.3 m 27'	*14350 *31,650	*14350 *31,650	*15750 *34,800	11650 25,750	*11900 *26,300	7550 16,700	9000 19,800	5500 12,100			7900 17,450	4850 10,700
-3.0 m -10'	7.5 m 24'	*17400 *38,400	*17400 *38,400	*13750 *30,300	11850 26,150	*10550 *23,250	7650 16,850					*8000 *17,700	5750 12,700
-4.6 m -15'	6.1 m 20'	*12450 *27,500	*12450 *27,500	*10200 *22,550	*10200 *22,550	*7450 *16,400	*7450 *16,400					*7350 *16,300	*7350 *16,300

PC300LC-7		Shoe 850 mm 33'5"										Unit: kg/lb	
B	A MAX	3.0 m 10'		4.6 m 15'		6.1 m 20'		7.6 m 25'		9.1 m 30'		⊗ MAX	
		Cf	Cs	Cf	Cs	Cf	Cs	Cf	Cs	Cf	Cs	Cf	Cs
7.6 m 25'	7.1 m 23'											*7600 *16,850	7400 16,400
6.1 m 20'	8.1 m 26'							*7950 *17,550	6450 14,200			*7450 *16,450	5800 12,800
4.6 m 15'	8.7 m 28'			*12550 *27,700	*12550 *27,700	*9800 *21,600	9000 19,850	*8350 *18,450	6250 13,800			*7650 *16,850	4950 11,000
3.0 m 10'	9.0 m 29'			*15200 *33,550	12950 28,550	*11000 *24,300	8450 18,650	*8900 *19,700	6000 13,250			7300 16,150	4550 10,050
1.5 m 5'	9.0 m 30'			*16800 *37,050	12050 26,600	*11950 *26,400	7950 17,600	9300 20,500	5750 12,650			7100 15,700	4400 9,700
0 m 0'	8.8 m 29'			*16800 *37,050	11750 25,900	*12300 *27,200	7700 16,950	9100 20,050	5550 12,300			7300 16,150	4500 9,900
-1.5 m -5'	8.3 m 27'	*14350 *31,650	*14350 *31,650	*15750 *34,800	11700 25,900	*11900 *26,300	7600 16,750	9050 19,950	5500 12,150			7950 17,550	4900 10,800
-3.0 m -10'	7.5 m 24'	*17400 *38,400	*17400 *38,400	*13750 *30,300	11900 26,300	*10550 *23,250	7650 16,950					*8000 *17,700	5800 12,750
-4.6 m -15'	6.1 m 20'	*12450 *27,500	*12450 *27,500	*10200 *22,550	*10200 *22,550	*7450 *16,400	*7450 *16,400					*7350 *16,300	*7350 *16,300

*Load is limited by hydraulic capacity rather than tipping. Ratings are based on ISO standard No. 10567. Rated loads do not exceed 87% of hydraulic lift capacity or 75% of tipping load.

PC300LC-7 HYDRAULIC EXCAVATOR

LIFTING CAPACITIES



LIFTING CAPACITY

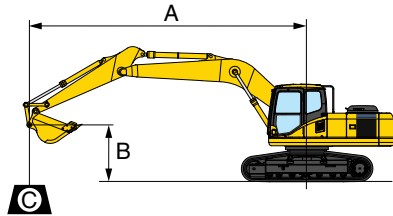

- A: Reach from swing center
- B: Bucket hook height
- C: Lifting capacity
- Cf: Rating over front
- Cs: Rating over side
- ☉: Rating at maximum reach

Conditions:

- Arm: 3185 mm 10'5"
- Boom length 6500 mm 21'3"
- Bucket 1.4 m³ 1.83 yd³ (SAE heaped)
- Bucket weight: 1021 kg 2,252 lb.

PC300LC-7		Shoe 700 mm 28"										Unit: kg/lb	
A B	MAX	3.0 m 10'		4.6 m 15'		6.1 m 20'		7.6 m 25'		9.1 m 30'		☉ MAX	
		Cf	Cs	Cf	Cs	Cf	Cs	Cf	Cs	Cf	Cs	Cf	Cs
7.6 m 25'	7.7 m 25'							*5950 *13,100	*5950 *13,100			*5350 *11,800	*5350 *11,800
6.1 m 20'	8.7 m 28'							*7300 *16,150	6450 14,250			*5250 *11,600	5050 11,200
4.6 m 15'	9.2 m 30'					*9050 *20,000	*9050 *20,000	*7800 *17,250	6250 13,800	*6000 *13,250	4500 9,950	*5350 *11,850	4400 9,750
3.0 m 10'	9.5 m 31'			*14050 *31,050	13250 29,200	*10400 *22,950	8500 18,800	*8500 *18,750	5950 13,200	7000 15,500	4400 9,700	*5700 *12,550	4050 8,950
1.5 m 5'	9.6 m 31'			*16250 *35,900	12250 27,000	*11600 *25,550	8000 17,650	*9150 *20,150	5700 12,600	6850 15,150	4250 9,350	*6250 *13,800	3900 8,650
0 m 0'	9.6 m 31'	*8400 *18,550	*8400 *18,550	*17000 *37,450	11700 25,850	*12100 *27,750	7500 16,600	8950 19,750	5500 12,100	6750 14,900	4150 9,150	6500 14,350	3950 8,800
-1.5 m -5'	8.9 m 29'	*13650 *30,150	*13650 *30,150	*16450 *36,350	11550 25,500	*12150 *26,850	7450 16,500	8850 19,500	5350 11,850			7000 15,450	4250 9,450
-3.0 m -10'	8.1 m 27'	*20050 *44,200	*20050 *44,200	*14900 *32,900	11650 25,700	*11150 *24,600	7350 16,250	*8550 *18,850	5400 11,900			*7700 *16,950	4950 10,900
-4.6 m -15'	6.9 m 23'	*15800 *34,900	*15800 *34,900	*12050 *26,650	11950 26,350	*9050 *20,000	7650 16,950					*7500 *16,550	6400 14,150

PC300LC-7		Shoe 800 mm 31.5"										Unit: kg/lb	
A B	MAX	3.0 m 10'		4.6 m 15'		6.1 m 20'		7.6 m 25'		9.1 m 30'		☉ MAX	
		Cf	Cs	Cf	Cs	Cf	Cs	Cf	Cs	Cf	Cs	Cf	Cs
7.6 m 25'	7.7 m 25'							*5950 *13,100	*5950 *13,100			*5350 *11,800	*5350 *11,800
6.1 m 20'	8.7 m 28'							*7300 *16,150	6500 14,400			*5250 *11,600	5150 11,350
4.6 m 15'	9.2 m 30'					*9050 *20,000	*9050 *20,000	*7800 *17,250	6300 13,950	*6000 *13,250	4550 10,050	*5350 *11,850	4450 9,850
3.0 m 10'	9.5 m 31'			*14050 *31,050	13350 29,450	*10400 *22,950	8600 19,000	*8500 *18,750	6050 13,350	7100 15,700	4450 9,800	*5700 *12,550	4100 9,050
1.5 m 5'	9.6 m 31'			*16250 *35,900	12350 27,250	*11600 *25,550	8100 17,850	*9150 *20,150	5750 12,700	6950 15,350	4300 9,500	*6250 *13,800	3950 8,750
0 m 0'	9.4 m 31'	*8400 *18,550	*8400 *18,550	*17000 *37,450	11850 26,100	*12100 *26,750	7600 16,800	9050 20,000	5550 12,250	6850 15,100	4200 9,250	6600 14,550	4000 8,900
-1.5 m -5'	8.9 m 29'	*13650 *30,150	*13650 *30,150	*16450 *36,350	11700 25,800	*12150 *26,850	7550 16,700	8950 19,750	5450 12,000			7100 15,650	4300 9,550
-3.0 m -10'	8.1 m 27'	*20050 *44,200	*20050 *44,200	*14900 *32,900	11760 26,000	*11150 *24,600	7450 16,450	*8550 *18,850	5450 12,050			*7700 *16,950	5000 11,050
-4.6 m -15'	6.9 m 23'	*15800 *34,900	*15800 *34,900	*12050 *26,650	12050 26,600	*9050 *20,000	7750 17,150					*7500 *16,550	6500 14,300

*Load is limited by hydraulic capacity rather than tipping. Ratings are based on ISO standard No. 10567. Rated loads do not exceed 87% of hydraulic lift capacity or 75% of tipping load.



LIFTING CAPACITY

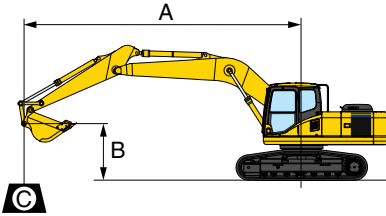

- A: Reach from swing center
- B: Bucket hook height
- C: Lifting capacity
- Cf: Rating over front
- Cs: Rating over side
- ☉: Rating at maximum reach

Conditions:

- Arm: 3185 mm **10'5"**
- Boom length 6500 mm **21'3"**
- Bucket 1.4 m³ **1.83 yd³** (SAE heaped)
- Bucket weight: 1021 kg **2,252 lb.**

PC300LC-7		Shoe 850 mm 33.5"										Unit: kg/lb		
B	A	MAX	3.0 m 10'		4.6 m 15'		6.1 m 20'		7.6 m 25'		9.1 m 30'		☉ MAX	
			Cf	Cs	Cf	Cs	Cf	Cs	Cf	Cs	Cf	Cs	Cf	Cs
7.6 m 25'	7.7 m 25'								*5950 *13,100	*5950 *13,100			*5350 *11,800	*5350 *11,800
6.1 m 20'	8.7 m 28'							*7300 *16,150	6550 14,500				*5250 *11,600	5150 11,400
4.6 m 15'	9.2 m 30'					*9050 *20,000	*9050 *20,000	*7800 *17,250	6350 14,000	*6000 *13,250	4550 10,100		*5350 *11,850	4500 9,900
3.0 m 10'	9.5 m 31'			*14050 *31,050	13400 29,600	*10400 *22,950	8650 19,050	*8500 *18,750	6050 13,400	7150 15,800	4450 9,850		*5700 *12,550	4100 9,100
1.5 m 5'	9.6 m 31'			*16250 *35,900	12400 27,400	*11600 *25,550	8100 17,950	*9150 *20,150	5800 12,800	7000 15,450	4300 9,550		*6250 *13,800	4000 8,800
0 m 0'	9.4 m 31'	*8400 *18,550	*8400 *18,550	*17000 *37,450	11900 26,250	*12100 *26,750	7650 16,900	9100 20,100	5600 12,350	6900 15,200	4200 9,300		6600 14,600	4050 8,950
-1.5 m -5'	8.9 m 29'	*13650 *30,150	*13650 *30,150	*16450 *36,350	11750 25,950	*12150 *26,850	7600 16,800	9000 19,850	5450 12,000				7100 15,750	4350 9,600
-3.0 m -10'	8.1 m 27'	*20050 *44,200	*20050 *44,200	*14900 *32,900	11850 26,100	*11150 *24,600	7500 16,550	*8550 *18,850	5500 12,150				*7700 *16,950	5000 11,100
-4.6 m -15'	6.9 m 23'	*15800 *34,900	*15800 *34,900	*12050 *26,650	*12050 *26,650	*9050 *20,000	7800 17,200						*7500 *16,550	6500 14,400

*Load is limited by hydraulic capacity rather than tipping. Ratings are based on ISO standard No. 10567. Rated loads do not exceed 87% of hydraulic lift capacity or 75% of tipping load.

PC300LC-7 HYDRAULIC EXCAVATOR

LIFTING CAPACITIES



LIFTING CAPACITY

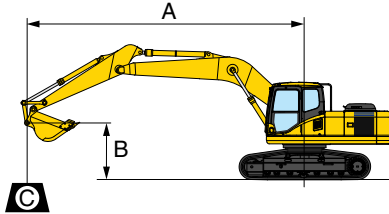

- A: Reach from swing center
- B: Bucket hook height
- C: Lifting capacity
- Cf: Rating over front
- Cs: Rating over side
- ☉ : Rating at maximum reach

Conditions:

- Arm: 4020 mm 13'2"
- Boom length 6500 mm 21'3"
- Bucket 1.4 m³ 1.83 yd³ (SAE heaped)
- Bucket weight: 1021 kg 2,252 lb.

PC300LC-7		Shoe 700 mm 28"										Unit: kg/lb	
B	A MAX	3.0 m 10'		4.6 m 15'		6.1 m 20'		7.6 m 25'		9.1 m 30'		☉ MAX	
		Cf	Cs	Cf	Cs	Cf	Cs	Cf	Cs	Cf	Cs	Cf	Cs
7.6 m 25'	8.8 m 29'											*4150 *9,200	*4150 *9,200
6.1 m 20'	9.6 m 31'									*5600 *12,350	4750 10,550	*4050 *9,000	*4050 *9,000
4.6 m 15'	10.1 m 33'							*7150 *15,750	6450 14,250	*6550 *14,450	4650 10,300	*4100 *9,100	3800 8,450
3.0 m 10'	10.4 m 34'	*19600 *43,250	*19600 *43,250	*12400 *27,400	*12400 *27,400	*9450 *20,900	8800 19,400	*7900 *17,450	6150 13,550	*6950 *15,300	4500 9,900	*4300 *9,500	3550 7,850
1.5 m 5'	10.4 m 34'	*8750 *19,350	*8750 *19,350	*15050 *33,200	12550 27,760	*10850 *23,950	8150 18,000	*8650 *19,150	5800 12,800	6950 15,300	4300 9,500	*4650 *10,250	3400 7,550
0 m 0'	10.2 m 34'	*9150 *20,250	*9150 *20,250	*16500 *36,450	11750 25,950	*11800 *26,100	7700 16,950	9000 19,850	5500 12,150	6750 14,950	4150 9,150	*5150 *11,400	3450 7,600
-1.5 m -5'	9.8 m 32'	*12350 *27,250	*12350 *27,250	*16700 *36,850	11400 25,150	*12150 *26,800	7400 16,350	8800 19,400	5300 11,750	6650 14,700	4050 8,950	*6000 *13,250	3650 8,050
-3.0 m -10'	9.1 m 30'	*16900 *37,250	*16900 *37,250	*15800 *34,850	11350 25,050	*11700 *25,850	7300 16,150	8700 19,250	5250 11,650			6750 14,850	4100 9,050
-4.6 m -15'	8.0 m 26'	*19100 *42,100	*19100 *42,100	*13750 *30,300	11550 25,450	*10300 *22,750	7400 16,350	*7650 *16,900	5350 11,850			*6950 *15,300	5000 11,050
-6.1 m -20'	6.4 m 21'	*13300 *29,300	*13300 *29,300	*9950 *22,000	*9950 *22,000	*7150 *15,800	*7150 *15,800					*6450 *14,250	*6450 *14,250

PC300LC-7		Shoe 800 mm 31.5"										Unit: kg/lb	
B	A MAX	3.0 m 10'		4.6 m 15'		6.1 m 20'		7.6 m 25'		9.1 m 30'		☉ MAX	
		Cf	Cs	Cf	Cs	Cf	Cs	Cf	Cs	Cf	Cs	Cf	Cs
7.6 m 25'	8.8 m 29'											*4150 *9,200	*4150 *9,200
6.1 m 20'	9.6 m 31'									*5600 *12,350	4800 10,650	*4050 *9,000	*4050 *9,000
4.6 m 15'	10.1 m 33'							*7150 *15,750	6500 14,400	*6550 *14,450	4700 10,400	*4100 *9,100	3850 8,550
3.0 m 10'	10.4 m 34'	*19600 *43,250	*19600 *43,250	*12400 *27,400	*12400 *27,400	*9450 *20,900	8850 19,600	*7900 *17,450	6200 13,700	*6950 *15,300	4550 10,050	*4300 *9,500	3600 7,950
1.5 m 5'	10.4 m 34'	*8750 *19,350	*8750 *19,350	*15050 *33,200	12700 28,000	*10850 *23,950	8250 18,200	*8650 *19,150	5850 12,950	7000 15,500	4350 9,600	*4650 *10,250	3450 7,650
0 m 0'	10.2 m 34'	*9150 *20,250	*9150 *20,250	*16500 *36,450	11900 26,200	*11800 *26,100	7750 17,150	9100 20,050	5550 12,300	6850 15,150	4200 9,250	*5150 *11,400	3500 7,700
-1.5 m -5'	9.8 m 32'	*12350 *27,250	*12350 *27,250	*16700 *36,850	11550 25,450	*12150 *26,800	7500 16,550	8900 19,650	5400 11,900	6750 14,900	4100 9,050	*6000 *13,250	3700 8,150
-3.0 m -10'	9.1 m 30'	*16900 *37,250	*16900 *37,250	*15800 *34,850	11600 25,350	*11700 *25,850	7400 16,350	8850 19,500	5350 11,800			6800 15,050	4150 9,150
-4.6 m -15'	8.0 m 26'	*19100 *42,100	*19100 *42,100	*13750 *30,300	11650 25,750	*10300 *22,750	7500 16,550	*7650 *16,900	5450 12,000			*6950 *15,300	5050 11,200
-6.1 m -20'	6.4 m 21'	*13300 *29,300	*13300 *29,300	*9950 *22,000	*9950 *22,000	*7150 *15,800	*7150 *15,800					*6450 *14,250	*6450 *14,250

*Load is limited by hydraulic capacity rather than tipping. Ratings are based on ISO standard No. 10567. Rated loads do not exceed 87% of hydraulic lift capacity or 75% of tipping load.



LIFTING CAPACITY

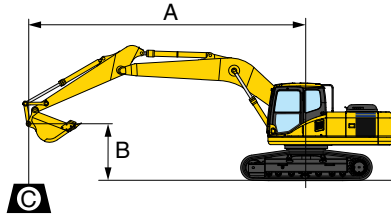

- A: Reach from swing center
- B: Bucket hook height
- C: Lifting capacity
- Cf: Rating over front
- Cs: Rating over side
- ⊗: Rating at maximum reach

Conditions:

- Arm: 4020 mm 13'2"
- Boom length 6500 mm 21'3"
- Bucket 1.4 m³ 1.83 yd³ (SAE heaped)
- Bucket weight: 1021 kg 2,252 lb.

PC300LC-7		Shoe 850 mm 33.5"										Unit: kg/lb		
A	B	MAX	3.0 m 10'		4.6 m 15'		6.1 m 20'		7.6 m 25'		9.1 m 30'		⊗ MAX	
			Cf	Cs	Cf	Cs	Cf	Cs	Cf	Cs	Cf	Cs	Cf	Cs
7.6 m 25'	8.8 m 29'												*4150 *9,200	*4150 *9,200
6.1 m 20'	9.6 m 31'									*5600 *12,350	4850 10,700		*4050 *9,000	*4050 *9,000
4.6 m 15'	10.1 m 33'							*7150 *15,750	6550 14,500	*6550 *14,450	4750 10,450		*4100 *9,100	3900 8,600
3.0 m 10'	10.4 m 34'	*19600 *43,250	*19600 *43,250	*12400 *27,400	*12400 *27,400	*9450 *20,900	8900 19,650	*7900 *17,450	6200 13,750	*6950 *15,300	4550 10,100		*4300 *9,500	3600 8,000
1.5 m 5'	10.4 m 34'	*8750 *19,350	*8750 *19,350	*15050 *33,200	12750 28,150	*10850 *23,950	8300 18,300	*8650 *19,150	5900 13,000	7050 15,600	4350 9,650		*4650 *10,250	3500 7,700
0 m 0'	10.2 m 34'	*9150 *20,250	*9150 *20,250	*16500 *36,450	11950 26,350	*11800 *26,100	7800 17,250	9150 20,200	5600 12,400	6900 15,200	4200 9,300		*5150 *11,400	3500 7,750
-1.5 m -5'	9.8 m 32'	*12350 *27,250	*12350 *27,250	*16700 *36,850	11600 25,600	*12150 *26,800	7550 16,650	8950 19,750	5400 12,000	6800 15,000	4100 9,100		*6000 *13,250	3700 8,200
-3.0 m -10'	9.1 m 30'	*16900 *37,250	*16900 *37,250	*15800 *34,850	11550 25,500	*11700 *25,850	7450 16,450	8900 19,600	5350 11,850				6850 15,150	4150 9,200
-4.6 m -15'	8.0 m 26'	*19100 *42,100	*19100 *42,100	*13750 *30,300	11750 25,900	*10300 *22,750	7550 16,650	*7650 *16,900	5450 12,100				*6950 *15,300	5100 11,250
-6.1 m -20'	6.4 m 21'	*13300 *29,300	*13300 *29,300	*9950 *22,000	*9950 *22,000	*7150 *15,800	*7150 *15,800						*6450 *14,250	*6450 *14,250

*Load is limited by hydraulic capacity rather than tipping. Ratings are based on ISO standard No. 10567. Rated loads do not exceed 87% of hydraulic lift capacity or 75% of tipping load.



STANDARD EQUIPMENT

- Alternator, 60 Ampere, 24V
- AM/FM radio
- Auto-decel
- Automatic air conditioner with defroster
- Automatic deaeration system for fuel line
- Automatic engine warm-up system
- Batteries, large capacity
- Boom and arm holding valves
- Cab, damper mounted
- Counterweight 7371 kg **16,246 lb**
- Dry type air cleaner, double element
- Electric horn
- EMMS monitoring system
- Engine, Komatsu SAA6D114E-3
- Engine overheat prevention system
- Fan guard structure
- Fuel system 10 micron pre-filter
- High pressure in-line hydraulic filters
- Hydraulic track adjusters (each side)
- KOMTRAX
- Mirrors four (4), ISO compliant
- Multi-function color monitor
- Power maximizing system
- PPC hydraulic control system
- Radiator and oil cooler dustproof net
- Revolving frame deck guard
- Revolving frame undercovers
- Seat belt, retractable
- Seat, suspension
- Service valve (1 additional)
- Shoes, triple grouser: 800 mm **31.5"**
- Slip resistant foot plates
- Starting motor 11 kW/24V x 1
- Suction fan
- Track guiding guard, center section
- Travel alarm
- Two boom mode settings
- Working lights, 2 (boom and RH front)
- Working mode selection system



OPTIONAL EQUIPMENT

- Air ride suspension seat
- Arms
 - 2540 mm **8'4"** arm assembly
 - 3185 mm **10'5"** arm assembly
 - 3185 mm **10'5"** with one actuator piping
 - 4020 mm **13'2"** arm assembly
- Boom
 - 6500 mm **21'3"**
 - 6500 mm **21'3"** with one actuator piping
- Convertor, 12V
- Full front guard Level 1
- Full front guard Level 2
- One actuator hydraulic control unit
- Pattern change valve
- Rain visor
- Revolving frame undercovers, heavy duty
- Shoes, triple grouser: 700 mm **28"**
- Shoes, triple grouser: 850 mm **33.5"**
- Straight travel pedal
- Sun visor
- Top guard, Level 2 (FOG), bolt-on
- Track frame undercover, heavy duty
- Track roller guards (full length)
- Two actuator hydraulic control units
- Working light, front, one additional

KOMATSU®

